

THE SUPER HOBBY

KYOSHO®
THE FINEST RADIO CONTROL MODELS

PRINTED IN JAPAN

RADIO CONTROLLED, ENGINE-POWERED, BELT DRIVE, OFF-ROAD RACING BUGGY **CIRCUIT 1000 SERIES**

STINGER MK II™

- THE SOPHISTICATION OF FOUR-WHEEL DRIVE IN A .10-CLASS ENGINE-POWERED BUGGY.
- RACE-PROVEN FOUR-WHEEL INDEPENDENT SUSPENSION WITH DOUBLE WISHBONES AND OIL-FILLED SHOCKS.
- DESIGNED FOR RELIABILITY, WITH DRIVE BELT, TOUGH EX66 NYLON AND ALUMINUM PARTS.
- FRONT AND REAR DIFFERENTIALS THAT DISTRIBUTE ENGINE POWER MOST EFFECTIVELY TO THE FOUR WHEELS. GREAT TRACTION AND POWER!
- KIT INCLUDES HANDY "ZIP" STARTER FOR USE WITH MOST .11-SIZE MODEL ENGINES. (ELECTRIC STARTER CAN ALSO BE USED.)
- EASY ASSEMBLY WITH CLEAR INSTRUCTIONS. ALL PARTS SUPPLIED (EXCEPT ENGINE, RADIO GEAR).
 - SIMPLE ADJUSTMENTS FOR TOP HANDLING CHARACTERISTICS.

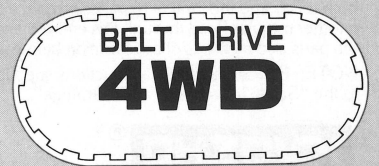

1:10 SCALE

ENGINE: .09-.12
RADIO: 2-CHANNEL
(NOT INCLUDED)

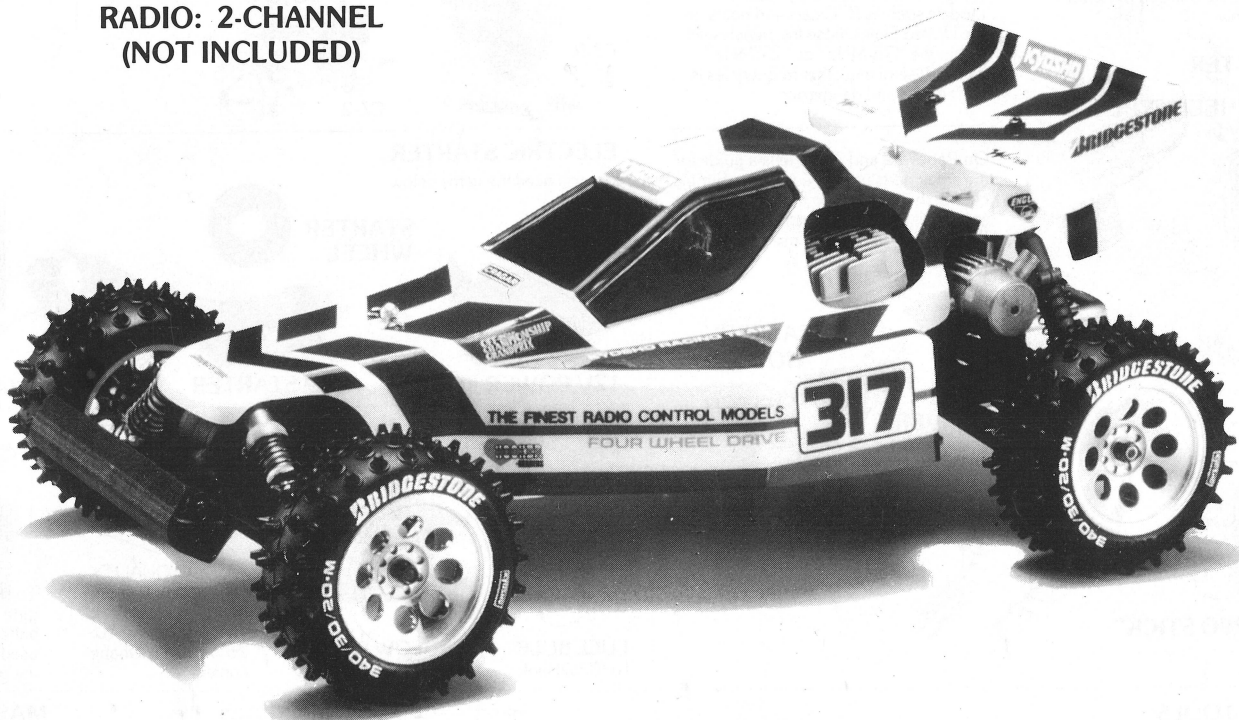

KYOSHO®
THE FINEST RADIO CONTROL MODELS

◀ KIT No.3042 ▶

ENTIRE CONTENTS © COPYRIGHT 1988, **HOBICO**™, INC.

STINGER MK II™

Before you begin, carefully read through the manual. This will give you a better understanding of the construction of this model:

Check the parts in the kit. Check to see if all parts are correctly bagged as they are listed in the list of "Bagged Parts" on pages 19 and 20.

Check all components prior to the beginning of your assembly. Any claims for replacement, refunds or parts shortages for this kit after you have started to assemble it, will not be accepted.

○ Certain symbols are used throughout the instructions. Pay attention to their location.

GREASE

... Points where **Grease** should be applied. (This will reduce wear and friction and provide a smoother operating joint.)

SW LOCK

Places where screw cement should be applied. (This will prevent screws and nuts from loosening up during operation due to the vibration of the model.)



... Where you see this guy, are steps that you should pay extra particular attention to when building this model.

IMPORTANT! BEFORE YOU BEGIN

A WORD OF WARNING is necessary, especially if this happens to be your first gas-powered vehicle. Gas-powered cars are subjected to stress and strain due to high engine RPM, rough terrain and the racing/high performance usage that they receive. As a result, they need continual preventative maintenance to keep them in operating condition.

This is a sophisticated model with a large number of moving parts. Before you begin assembly, take a look through the box and read the instructions carefully to decide whether or not you are ready for this challenge! If you do not feel that this type of model is for you, it may be returned to the dealer as long as it is NEW and UNUSED. UNDER NO CIRCUMSTANCES CAN YOUR DEALER ACCEPT A KIT FOR RETURN IF ASSEMBLY HAS ALREADY BEGUN! If this is not what you bargained for, then go no further and return this kit to the dealer immediately. BUT, if a little maintenance doesn't bother you and the thrill of high performance driving is for you, then don't hesitate another minute! Read through this entire manual thoroughly to familiarize yourself with the parts and methods of construction before actually starting to build.

NOTE: Please refer to the instructions supplied with your engine. Pay particular attention to the "Safety Instructions and Warnings".

KYOSHO®

ENTIRE CONTENTS
© COPYRIGHT 1988, HOBBICO, INC.

2 CHANNEL RADIO SYSTEM

A two channel, two servo radio control system is required for running the Stinger MKII 4WD. The various components are pictured below.

Note: use only radio frequencies specifically allowed to operate "surface" models such as R/C cars and boats. In the United States those frequencies fall within the "75 MHz" or "27 MHz" bands. Use of any other frequencies is both illegal and dangerous.

TRANSMITTER

"WHEEL TYPE"

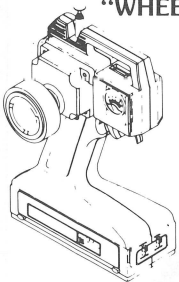

On Pages 22 and 23 there is a guide for the small parts used in each step. Simply cut out the sheet along the dotted line and use it to help you locate the particular parts and their shape used in each step.



RECEIVER

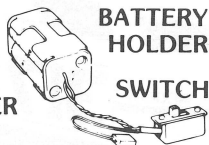

BATTERY HOLDER
SWITCH

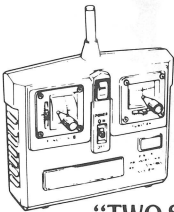

"TWO STICK"

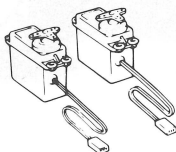

SERVOS

REQUIRED TOOLS

These are not included with the Stinger MKII.

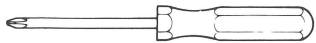

PHILIPS HEAD SCREW DRIVER



NUT DRIVER



HOBBY KNIFE

NEEDLE NOSE PLIERS



HOBBY SHEARS



BODY SANDER

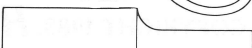

AWL

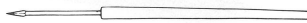

4-WAY
WRENCH

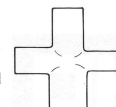

CONTACT CEMENT
CYANOACRYLATE
GLUE



BRUSH



POLYCA
PAINT



MASKING
TAPE

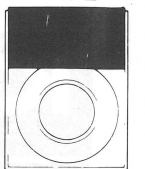

A few different types of screws are used in the construction of your model. Here are some examples of them and how they will be indicated in the instructions. For example, Self Tapping will simply be S/T screw.

SCREW

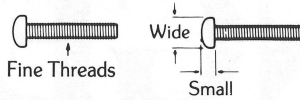

If it is an ordinary screw it will be marked "screw".

SELF TAPPING (S/T)

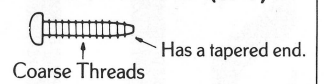

ALLEN HEAD SCREW (A/H)

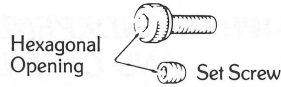

METRIC NUTS AND BOLTS

All nuts and bolts used throughout this kit are metric size. Therefore, some of the notations may not be familiar to you. An M3 nut is a 3 millimeter (3mm) nut. An M3 x 15 screw is 15mm long and 3mm in diameter. Some round parts may be labeled as a "4mm Washer" (this should be a washer with a 4mm inside diameter) or a "3mm Bushing" (a bushing with a 3mm inside diameter). For your reference, 1 millimeter equals approximately .039 inches.

M3x15 SCREW

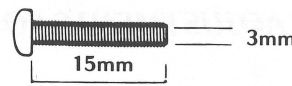

4mm WASHER

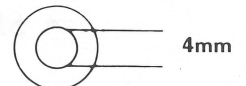

Use the list of small parts on pages 22 and 23 to compare the shapes of the small parts used with each step such as screws, nuts and washers.

Do not use excessive force when tightening S/T type screws into plastic. Overtightening will cause the threaded portion of the plastic to strip. It is recommended to stop tightening when some resistance is felt after the threaded portion enters the plastic.

Correct

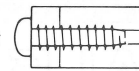

Wrong

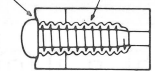

CZ-R

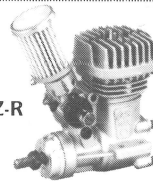

CZ-2

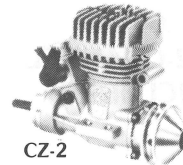

A .11-size engine is required. We recommend an O.S. CZ-2 or CZ-R.

ELECTRIC STARTER

You will need the items below.



12V POWER SOURCE

STARTER
WHEEL



12V STARTER



12V CHARGER

Items you will need for running the Stinger MKII 4WD.



FUEL BULB
To fill fuel tank.

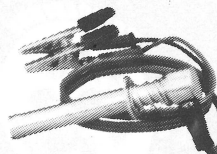

GLOW PLUG
BATTERY CORD



A GOOD QUALITY glow fuel is very important. Choose a blend with a 10-25% nitro-methane content.



To start the engine, a 1.5V battery will be used to heat the glow plug.

1 INSTALLATION OF THE JOINTS

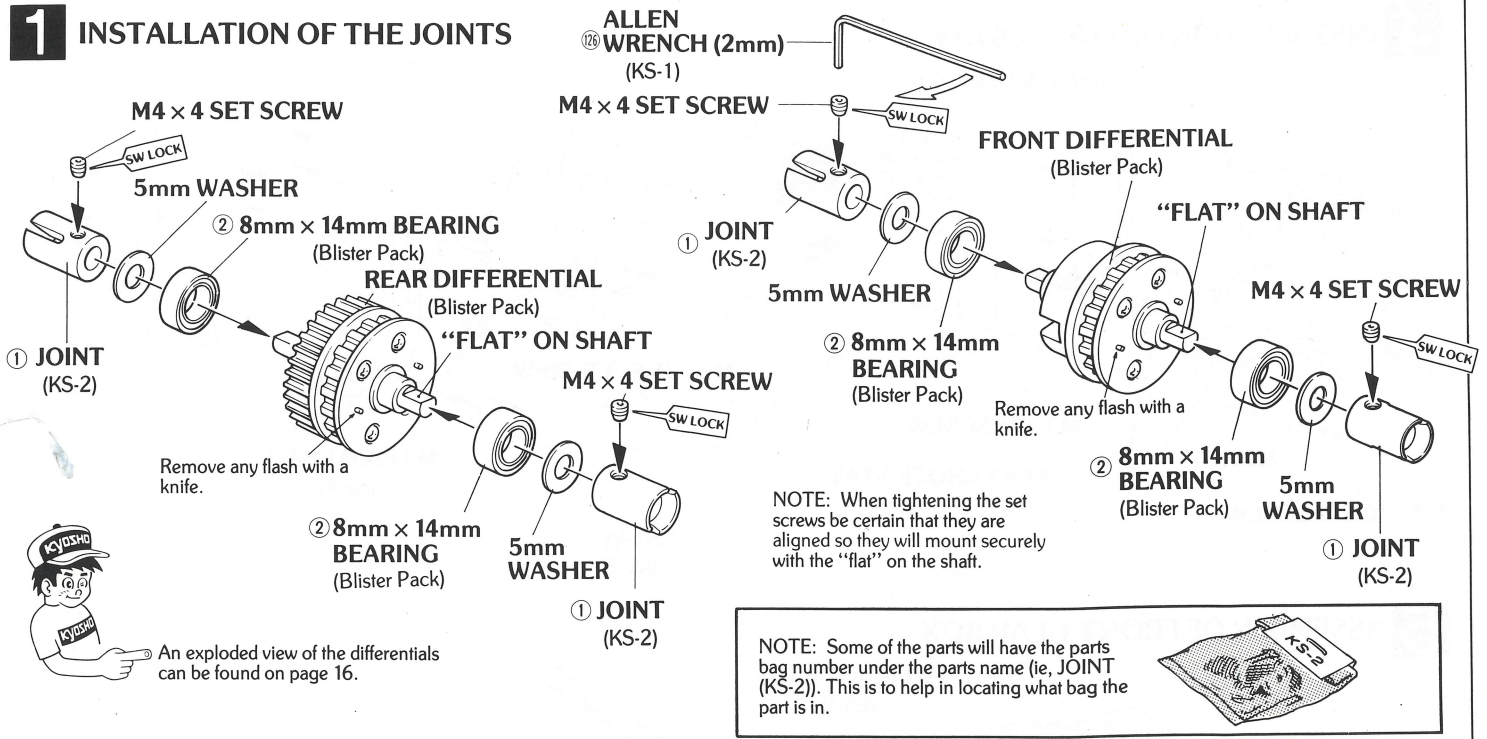

2 ASSEMBLY OF REAR GEAR BOX

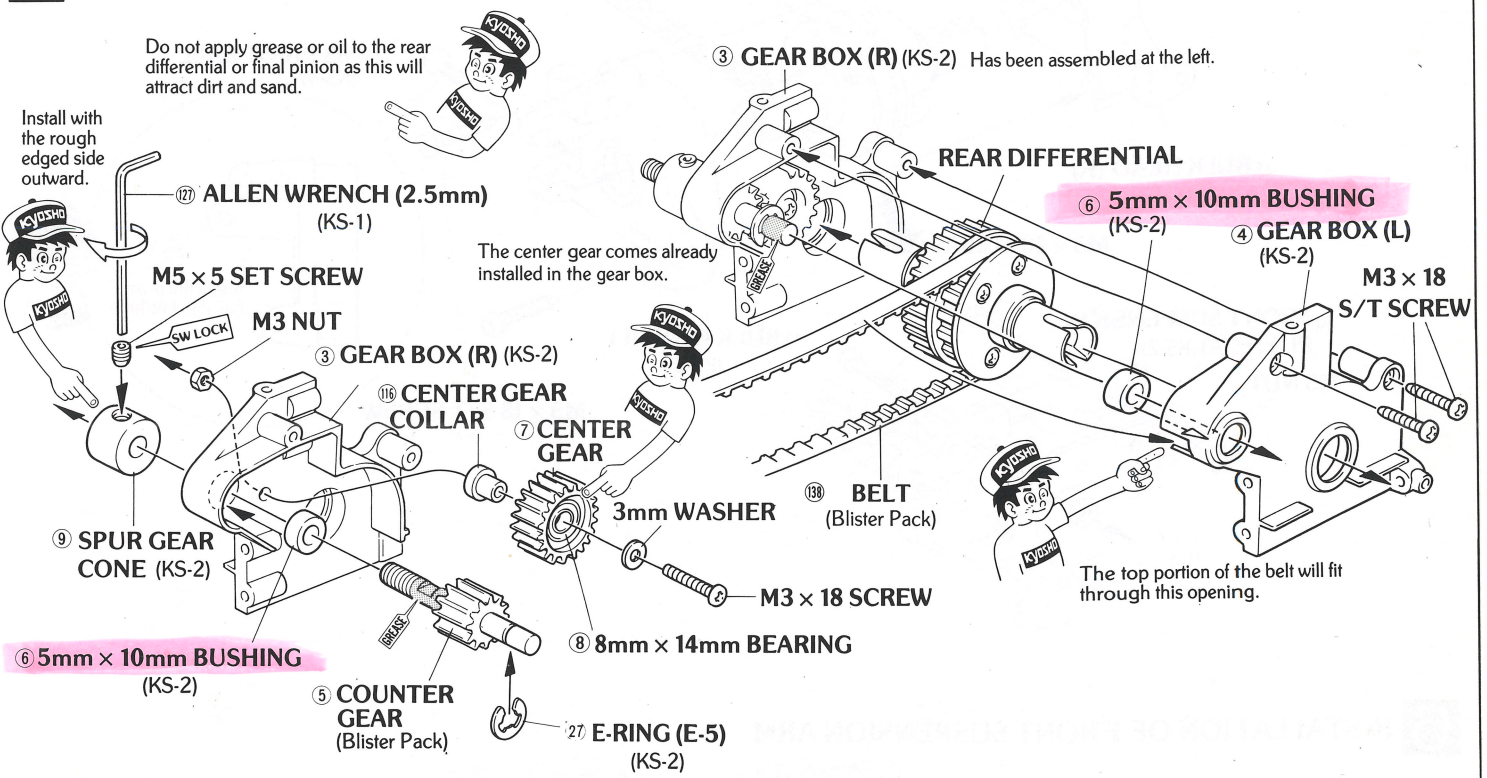

3 INSTALLATION OF REAR PLATE

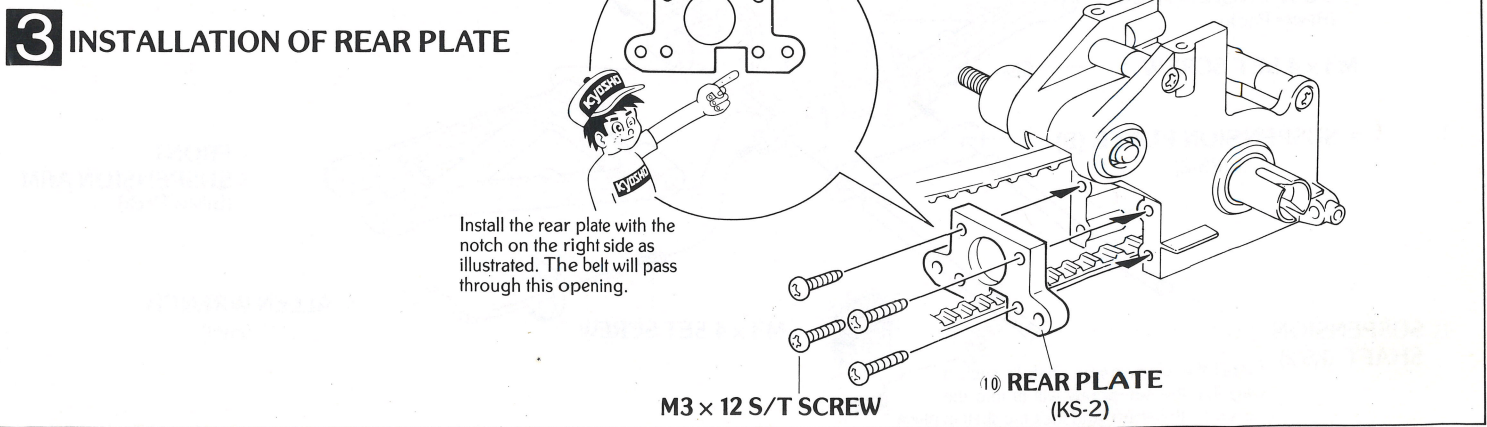

4 INSTALLATION OF SHOCK STAY

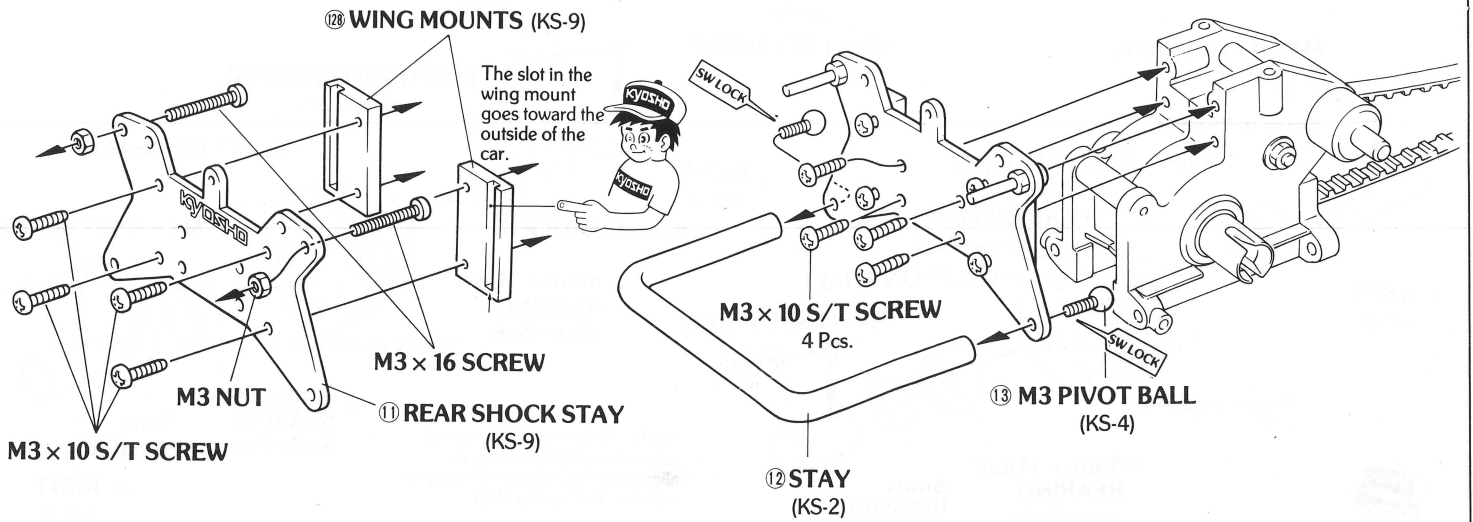

5 ASSEMBLY OF FRONT GEAR BOX

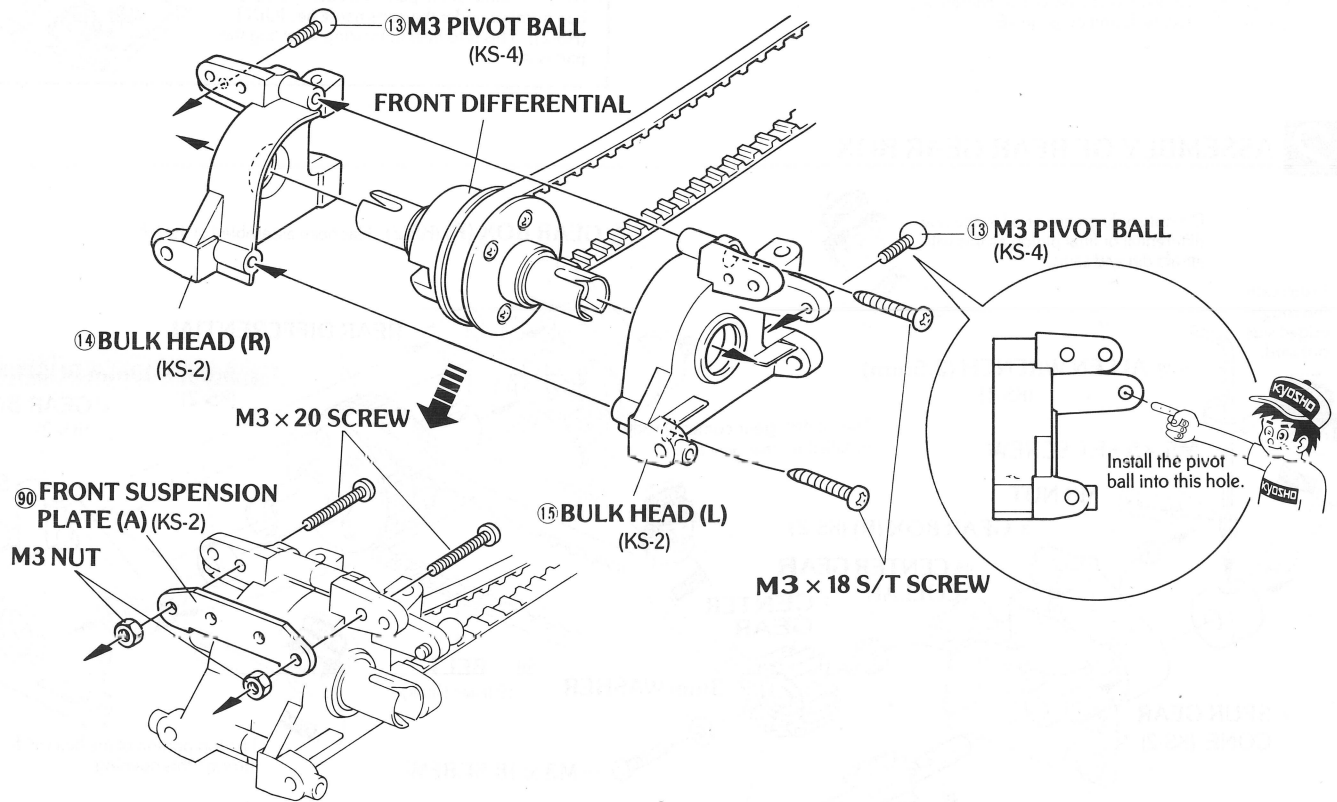

6 INSTALLATION OF FRONT SUSPENSION ARM

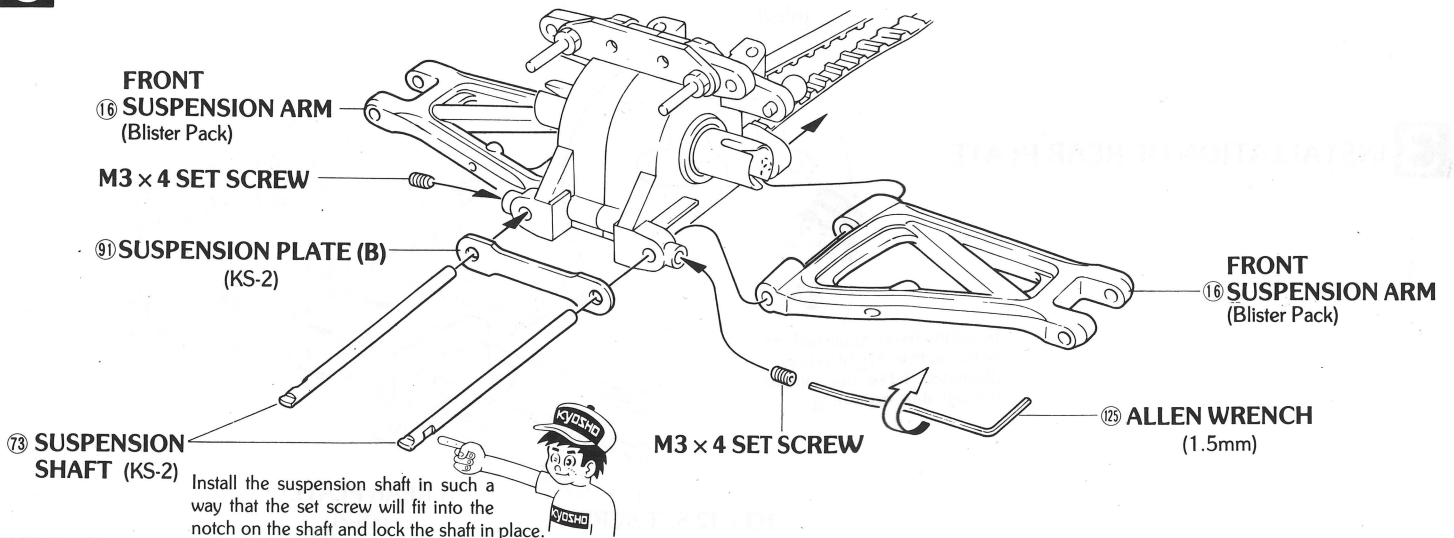

4 INSTALLATION OF SHOCK STAY

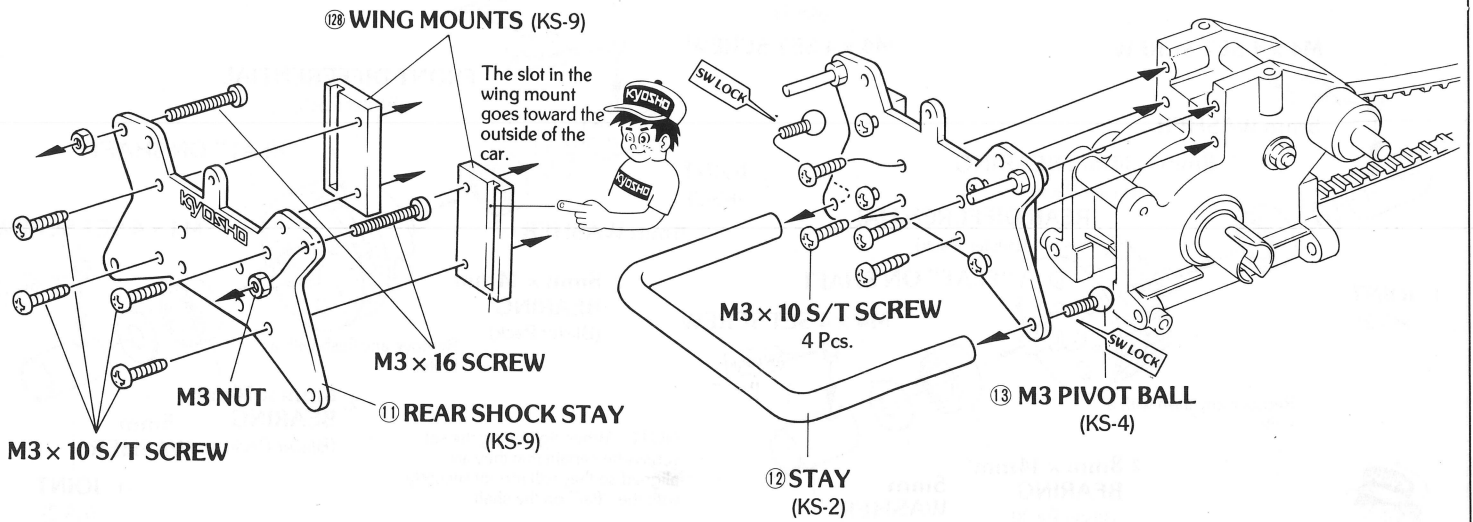

5 ASSEMBLY OF FRONT GEAR BOX

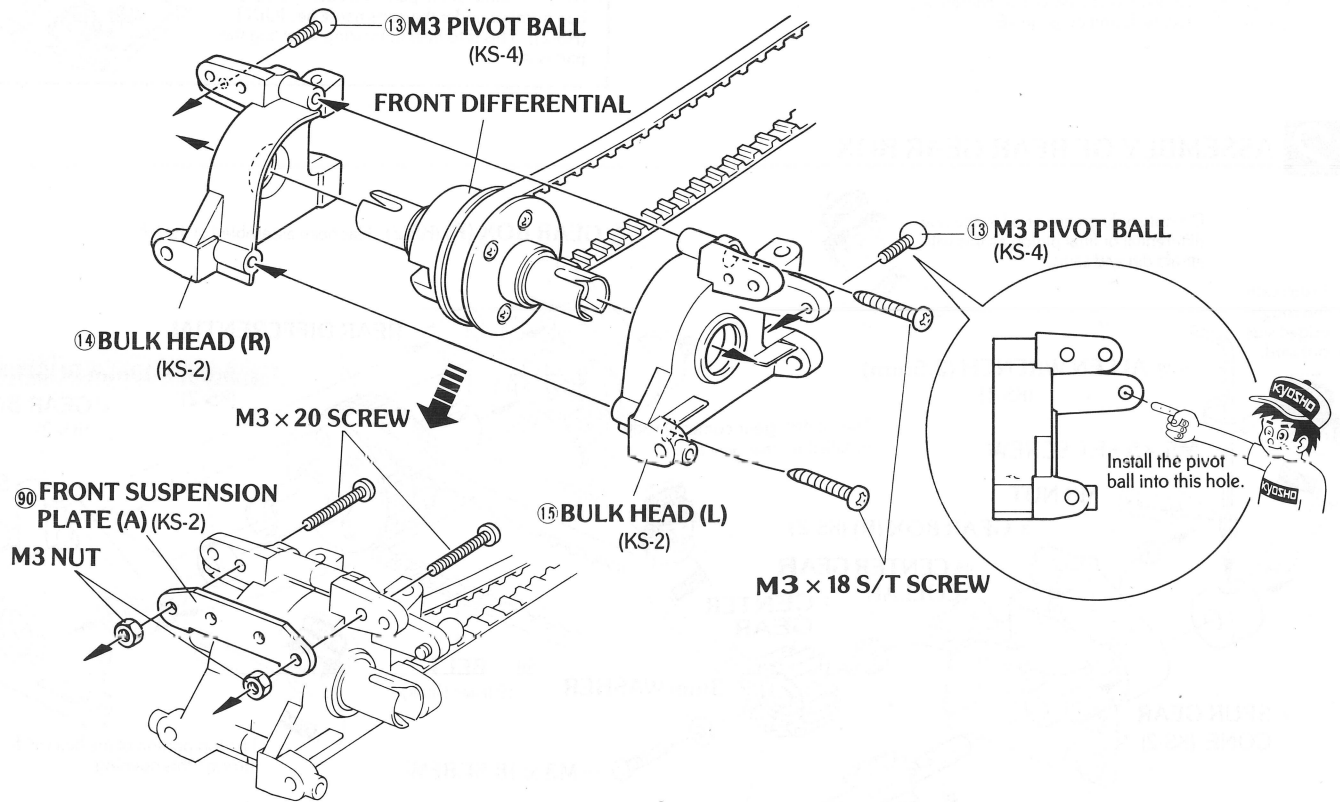

6 INSTALLATION OF FRONT SUSPENSION ARM

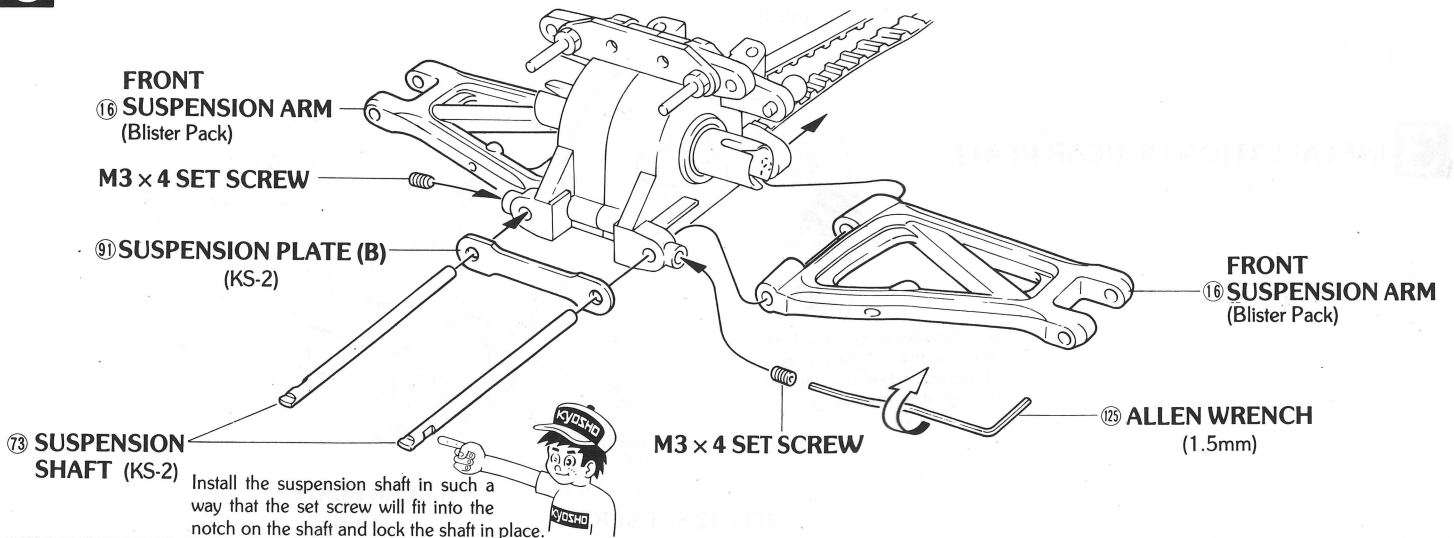

10 ASSEMBLY OF KNUCKLE ARMS

Use the left knuckle arm with the right hub.

1.

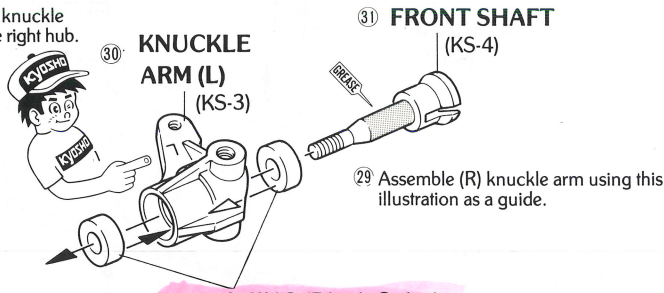

Be certain to use the hub marked "L" when assembling the left side.

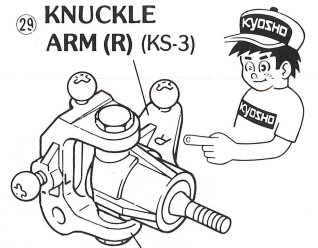

130 BUSHING (Black Color)
(5mm x 10mm)

2.

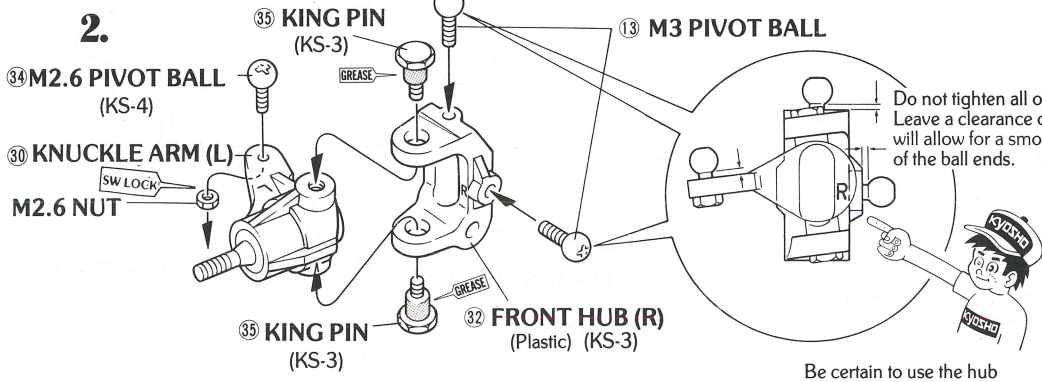

Be certain to use the hub marked "R" for the right side.

11 INSTALLATION OF KNUCKLE ARMS

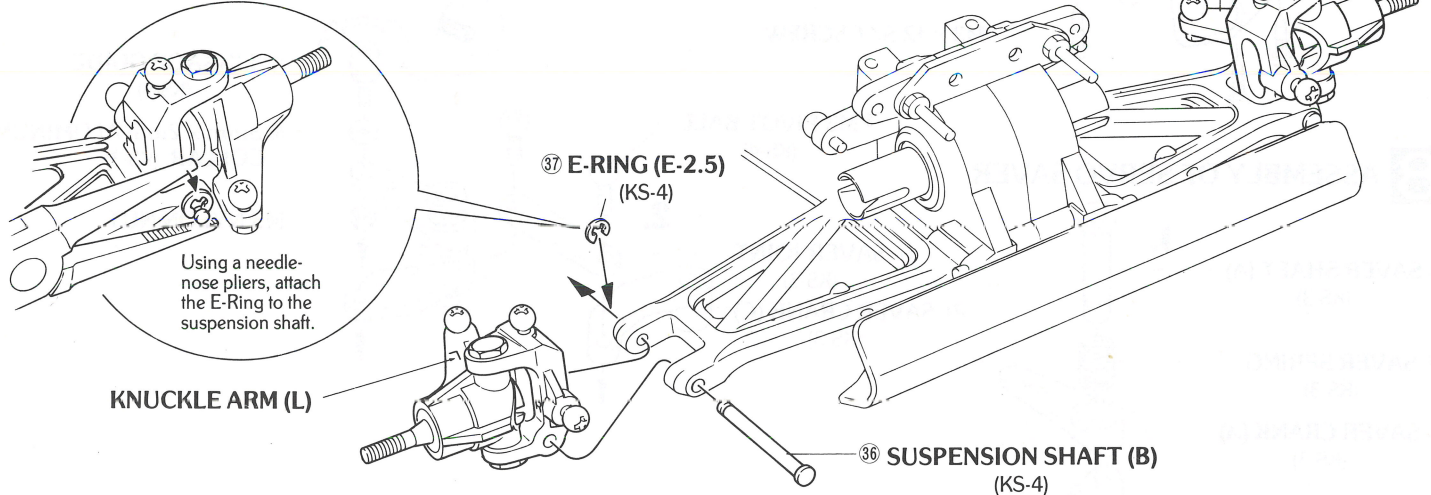

12 INSTALLATION OF FRONT UPPER RODS

Two upper rod assemblies will need to be made (one for each side).

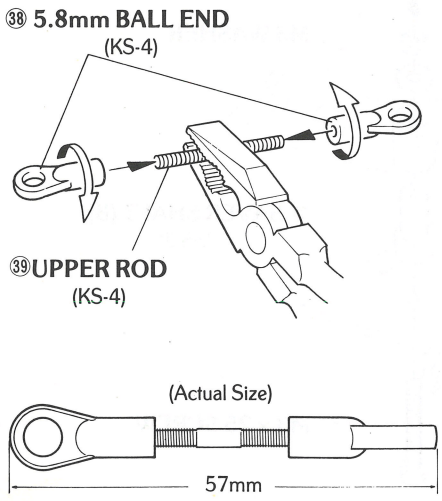

This is the upper rod that has been assembled in the illustration at the left.

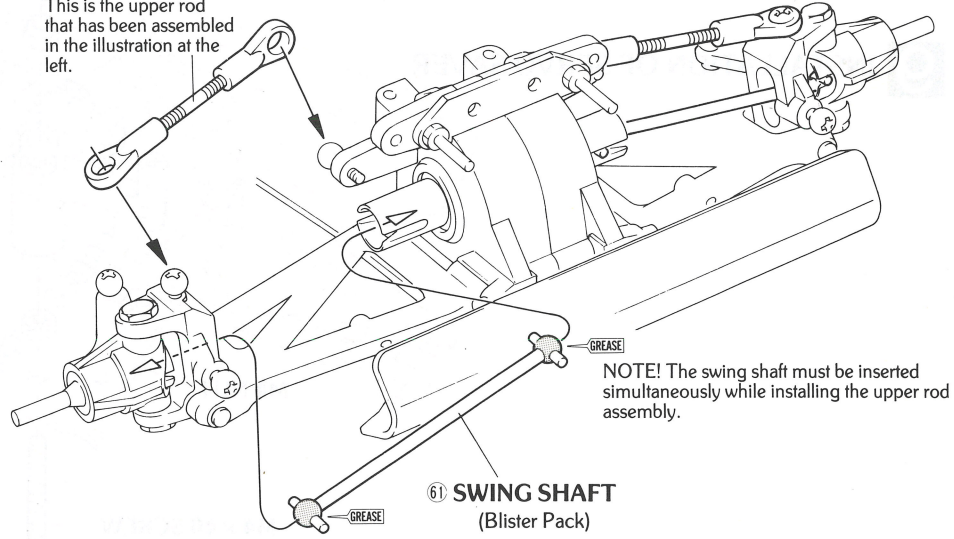

HOW TO USE THE ELECTRIC STARTER

For most type engines, you will need to obtain a starting wheel which attaches to your starter.

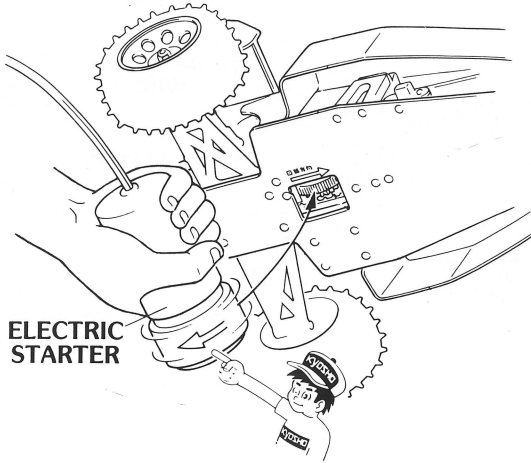

ELECTRIC STARTER

When using a starter on this car be very certain which way the starter is rotating the engine. These engines are designed and will only operate in one direction. The correct rotation of the engine is counter-clockwise while facing the engine from the clutch bell side of the engine. Use short, popping motions, while applying the starting wheel to the flywheel. Do not hold the starter on the flywheel for an extended period of time. If the engine has not started within the first few times, check the other components of the car using the trouble shooting diagram as a guide.

TROUBLE SHOOTING DIAGRAM

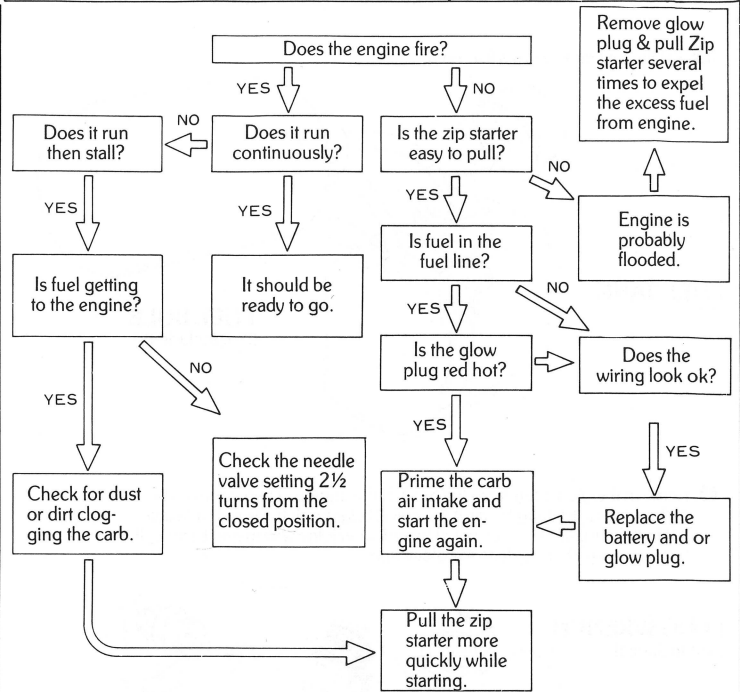

GUIDE TO KEY NUMBERS

No.	Parts Name	Q'ty	No.	Parts Name	Q'ty	No.	Parts Name	Q'ty	No.	Parts Name	Q'ty
①	Joint	.4	③⑧	5mm Ball End	.12	⑦⑤	Pilot Shaft (O.S.)	.1	①②	Torque Rod Mount	.1
②	8mm x 14mm Bearing	.4	③⑨	Upper Rod	.4	⑦⑥	Engine Mount (A) (Enya)	.1	①③	6.8mm Ball End	.2
③	Gear Box (R)	.1	④⑩	Shock Seal	.4	⑦⑦	Engine Mount (B) (Enya)	.1	①④	Body	.1
④	Gear Box (L)	.1	④①	Shock End	.4	⑦⑧	Engine Mount (C) (O.S.)	.1	①⑤	Body Pin	.2
⑤	Counter Gear	.1	④②	Shock Stopper	.4	⑦⑨	Engine Mount (D) (O.S.)	.1	①⑥	Center Gear Collar	.1
⑥	5mm x 10mm Bushing	.2	④③	Shock O-Ring	.4	⑧⑩	Muffler (A)	.1	①⑦	Muffler Baffle	.1
⑦	Center Gear	.1	④④	Shock Washer	.4	⑧①	Muffler (B)	.1	①⑧	Muffler Gasket	.1
⑧	8mm x 14mm Bearing	.1	④⑤	Shock Oil	.1	⑧②	Clutch Shoe	.2	①⑨	Chassis	.1
⑨	Spur Gear Cone	.1	④⑥	Shock Wrench	.1	⑧③	Clutch Spring	.1	②①	Radio Plate	.1
⑩	Rear Plate	.1	④⑦	Shock Piston (F)	.2	⑧④	E-Ring (E-7)	.1	②②	Radio Plate Post	.1
⑪	Rear Shock Stay	.1	④⑧	Shock Piston (R)	.2	⑧⑤	Clutch Bearing	.1	②③	6.8mm Ball	.1
⑫	Stay	.1	④⑨	Front Shock Case	.2	⑧⑥	Clutch Bell (14T)	.1	②④	Silicone Tube	.1
⑬	M3 Pivot Ball	.12	⑤⑩	Rear Shock Case	.2	⑧⑦	E-Ring (E-3)	.1	②⑤	Antenna Tube	.1
⑭	Bulk Head (R)	.1	⑤①	Shock Bushing	.4	⑧⑧	Pin	.1	②⑥	Allen Wrench (1.5mm)	.1
⑮	Bulk Head (L)	.1	⑤②	Tie Rod	.2	⑧⑨	Belt Guide	.1	②⑦	Allen Wrench (2mm)	.1
⑯	Front Susp. Arm	.2	⑤③	Rear Shaft	.2	⑨①	Front Susp. Plate (A)	.1	②⑧	Allen Wrench (2.5mm)	.1
⑰	Susp. Shaft (A)	.2	⑤④	Rear Hub (L)	.1	⑨②	Front Susp. Plate (B)	.1	②⑨	Wing Mount	.1
⑱	Bumper	.1	⑤⑤	Rear Hub (R)	.1	⑨③	Tank Mount	.1	③①	Switch Mount	.1
⑲	Saver Shaft (A)	.1	⑤⑥	Rear Susp. Arm	.2	⑨④	Servo Mount	.2	③②	5mm x 10mm Bushing	.8
⑳	Saver Spring	.1	⑤⑦	Susp. Shaft	.2	⑨⑤	Switch Cover	.1	③③	Differential Case	.1
㉑	Saver Crank (A)	.1	⑤⑧	Throttle Rod	.1	⑨⑥	Body Mount	.1	③④	Differential Ring	.2
㉒	Saver Crank (B)	.1	⑤⑨	5.8mm Ball	.2	⑨⑦	Brake	.1	③⑤	Sprocket	.2
㉓	Saver Crank (C)	.1	⑥①	Spur Gear (53T)	.1	⑨⑧	Torque Rod Ball	.1	③⑥	Bevel Gear (A)	.4
㉔	Saver Joint	.1	⑥②	Swing Shaft	.4	⑨⑨	Control Rod	.2	③⑦	Bevel Gear (B)	.4
㉕	Linkage Guide	.1	⑥③	Tire	.4	⑩①	Wing Clamp	.2	③⑧	Bevel Gear Shaft	.2
㉖	3mm x 2mm Aluminum Collar	.1	⑥④	Wheel (1)	.4	⑩②	Stopper	.2	③⑨	Main Gear	.1
㉗	E-Ring (E-5)	.2	⑥⑤	Wheel (2)	.4	⑩③	Fuel Tank	.1	④①	Belt	.1
㉘	Saver Shaft (B)	.1	⑥⑥	Wheel (3)	.4	⑩④	Tank Bushing	.1	④②	Front Spring	.2
㉙	Knuckle Arm (R)	.1	⑥⑦	Drive Washer	.4	⑩⑤	Tank Pipe	.1	④③	Rear Spring	.2
㉚	Knuckle Arm (L)	.1	⑥⑧	Zip-Starters	.1	⑩⑥	Packing	.1	④④	Spring Stopper	.4
㉛	Front Shaft	.2	⑥⑨	Flywheel	.1	⑩⑦	Cap	.1	④⑤	Spring Holder	.4
㉜	Front Hub (R)	.1	⑦①	Clutch Pin	.2	⑩⑧	Nylon Strap	.2	④⑥	Wing Mounting Rod	.1
㉝	Front Hub (L)	.1	⑦②	Starter Gear	.1	⑩⑨	Receiver Cover	.1	④⑦	Wing	.1
㉞	M2.6 Pivot Ball	.2	⑦③	Starter Claw	.2	⑩⑩	Air Filter Element	.1	④⑧	Decal	.1
㉟	King Pin	.4	⑦④	Ratchet Spring	.1	⑩⑪	Air Filter Holder	.1			
㊱	Susp. Shaft (B)	.2	⑦⑤	Susp. Shaft (D)	.2		Air Filter Adapter	.1			
㊲	E-Ring (E-2.5)	.4	⑦⑥	Pilot Shaft (Enya)	.1		Torque Rod	.1			

13 FILLING THE SHOCKS WITH OIL

1. Remove stopper and fill shock case with oil up to the line as shown in the illustration below.

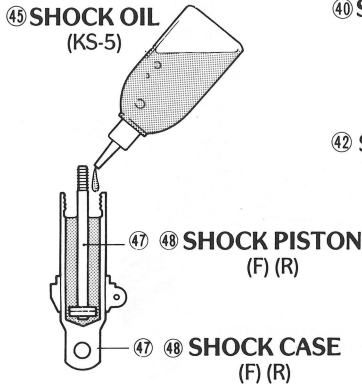

2. SHOCK END

2. Install the O-Ring and seal as shown.

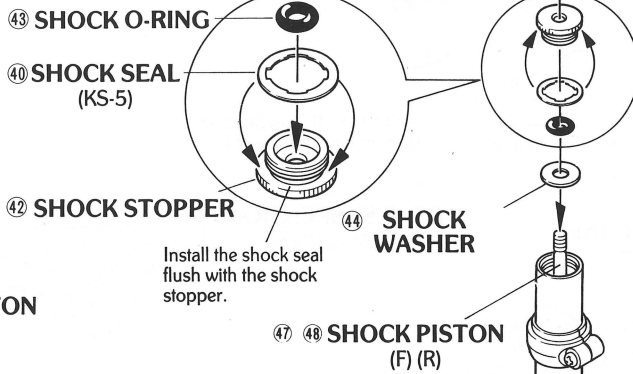

3. Using the shock wrench and an allen wrench as shown, tighten the shock stopper firmly against the shock case.

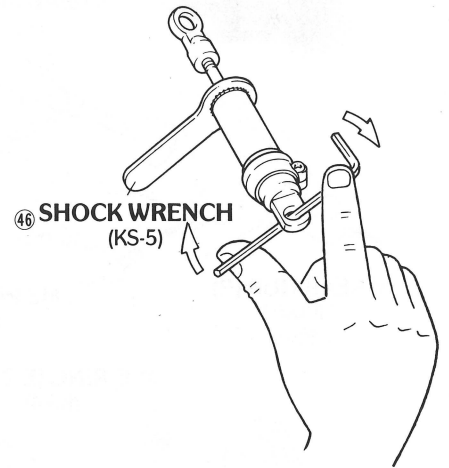

When installing the shock ends be certain that the front shocks are the same length as each other and that the rear shocks are the same length as each other.



Check the level of fluid in the case to see that it is at the proper level and that the shock can operate smoothly.

14 INSTALLATION OF FRONT SHOCKS

It may be easier to install the M3 x 12 screw with bushing first then snap the shock end onto the pivot ball.

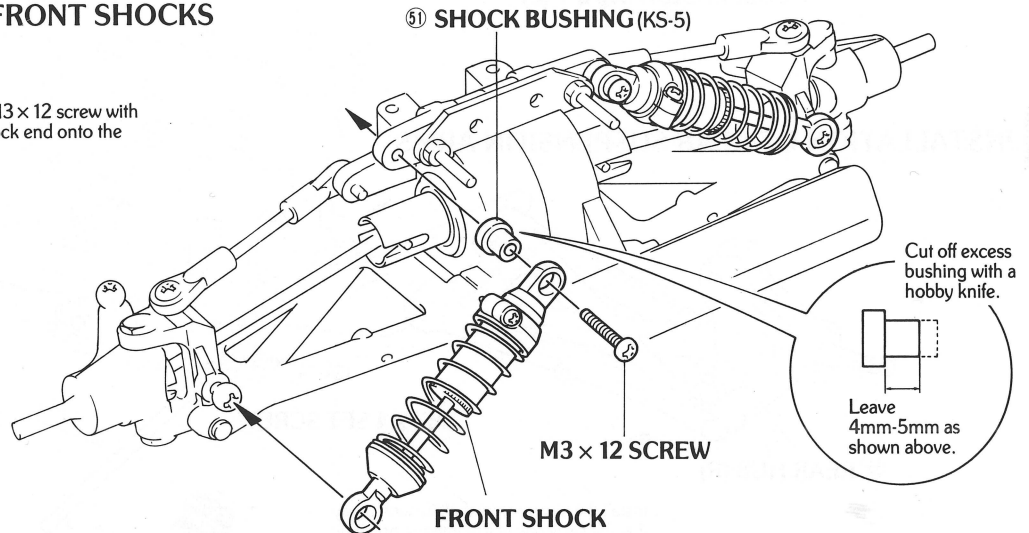

15 INSTALLATION OF THE TIE RODS

Install the tie rods by simply snapping the ball ends onto the appropriate pivot balls as shown.

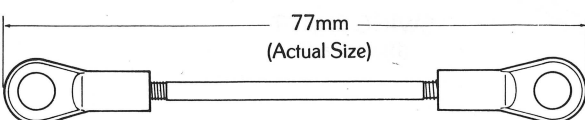
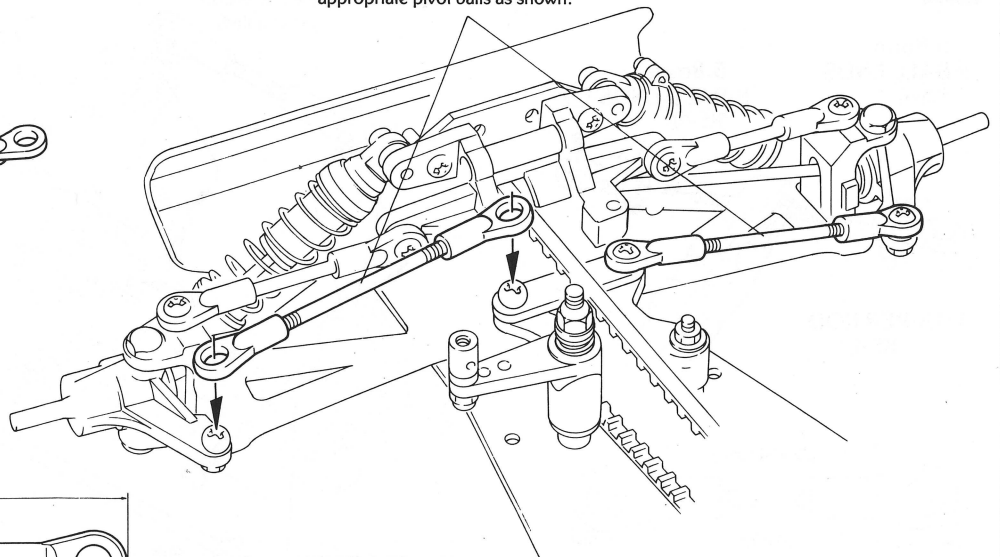
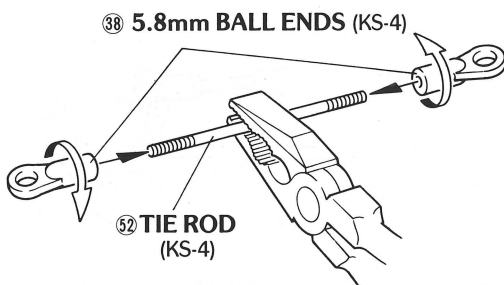

16 INSTALLATION OF REAR HUBS

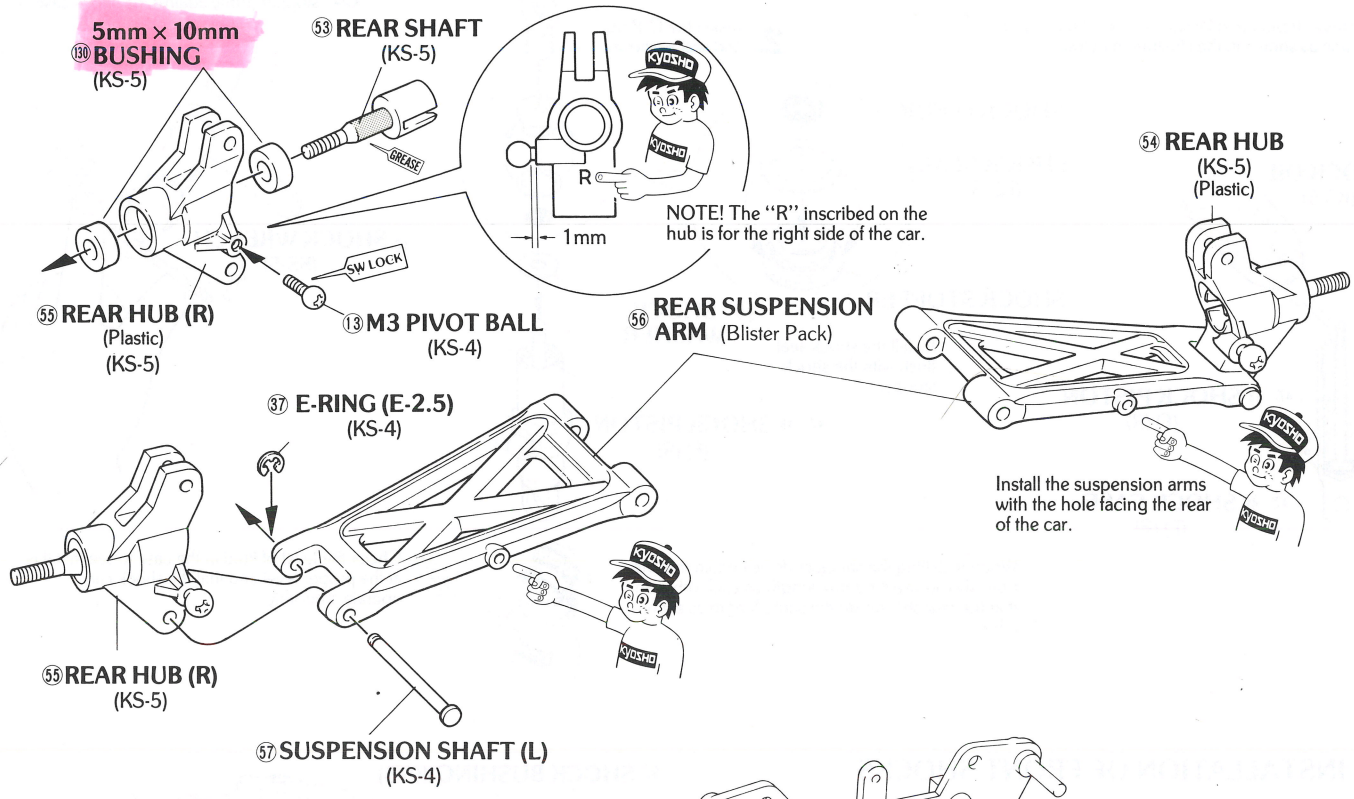

17 INSTALLATION OF REAR SUSPENSION ARMS

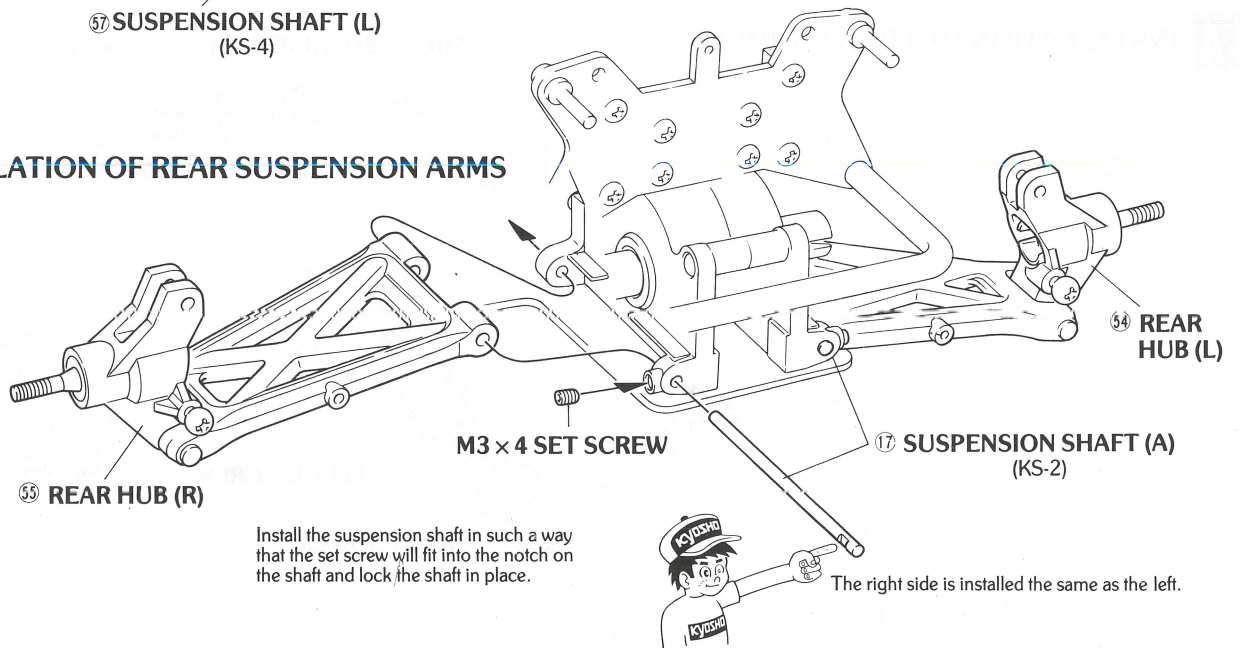

18 INSTALLATION OF REAR UPPER RODS

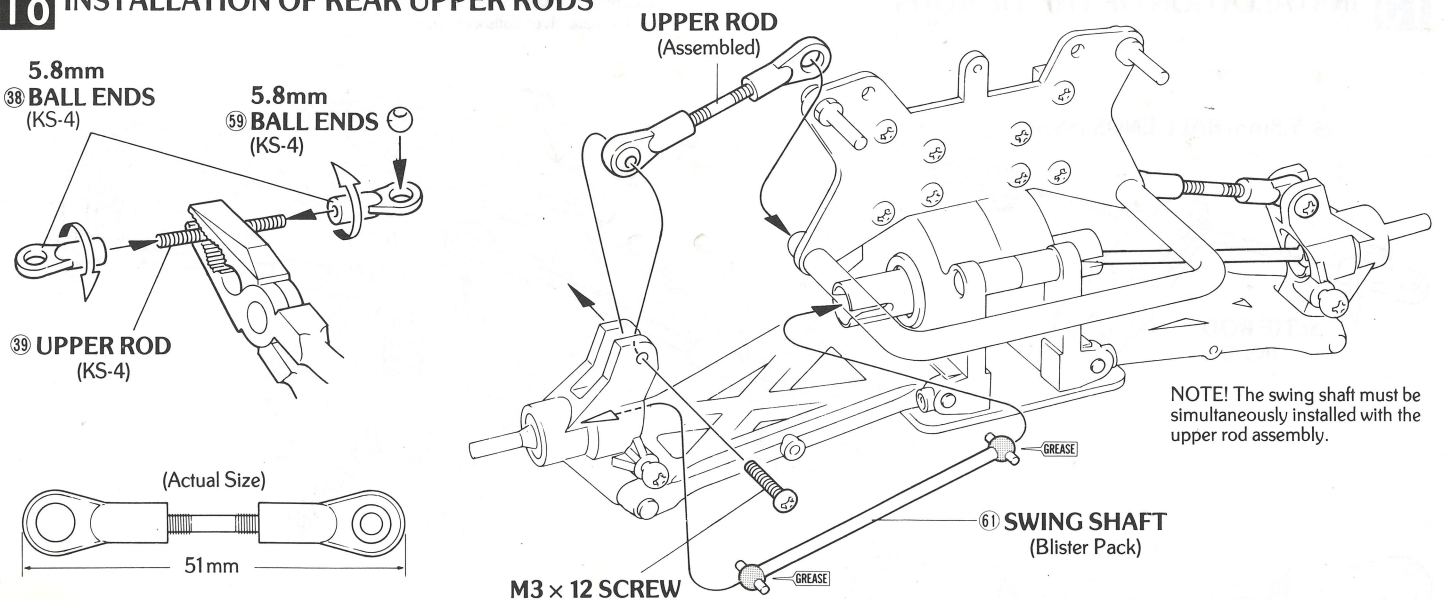

STARTING THE ENGINE

- 1 Fill the fuel tank using a fuel bulb.

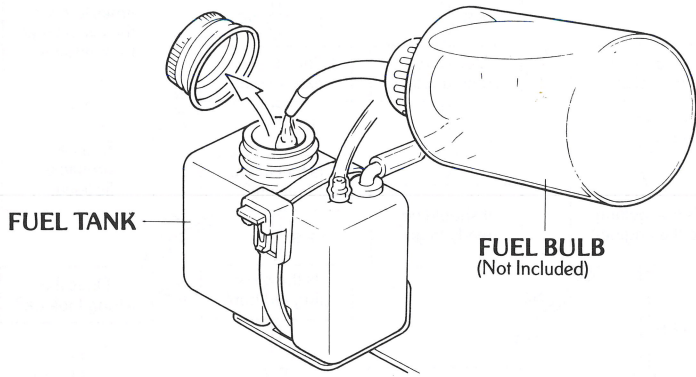

- 2 Remove the glow plug from the head of the engine. Then connect the battery clip to the plug to see if the coil is bright red. If it is red, reinstall it into the engine. If it does not glow red, check the wiring and battery. If they are okay, then replace the glow plug.

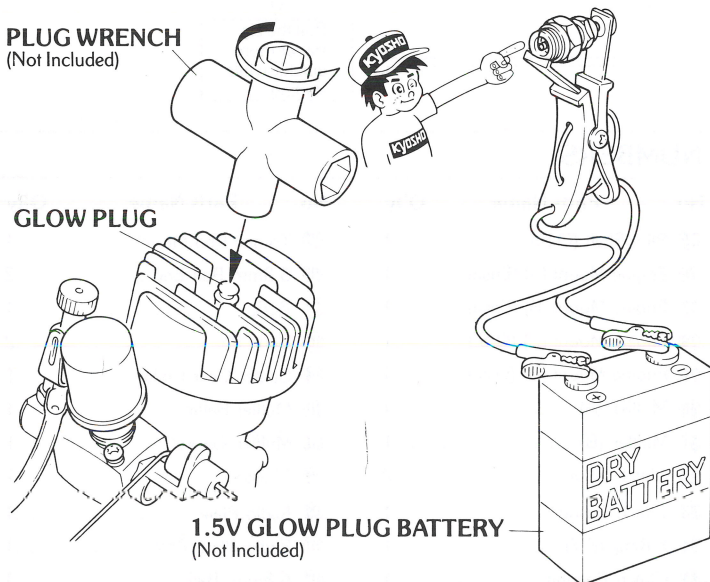

- 3 Place a small amount (2 to 3 drops) of fuel into the air filter element this will prime the engine and will also help trap small particles of dirt and sand.

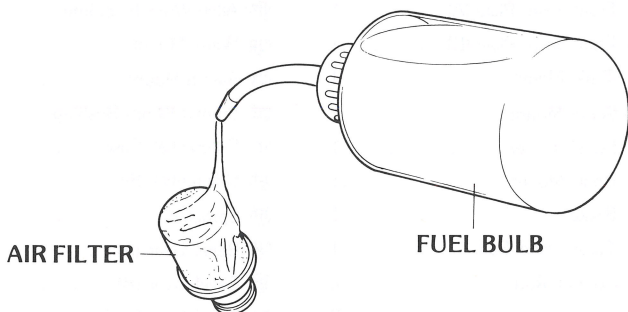

- 4 A few drops of fuel placed directly into the carb is very helpful in starting these type of glow engines.

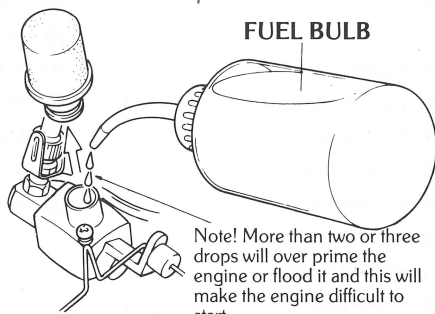

- 5 Refer to the engine instruction manual for the correct procedure of adjustment of the carb.

NEEDLE VALVE ADJUSTMENT

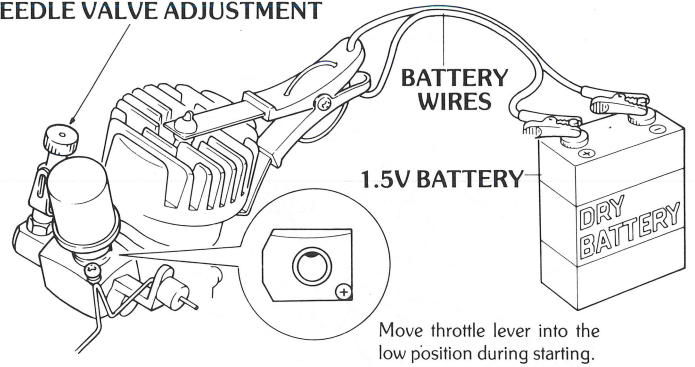

- 6 When using the zip starter, the body will need to be removed. Hold the model on its side as shown below. Insert the zip starter into the opening in the chassis. The teeth of the starter gear and the teeth of the zip starter should mesh together.

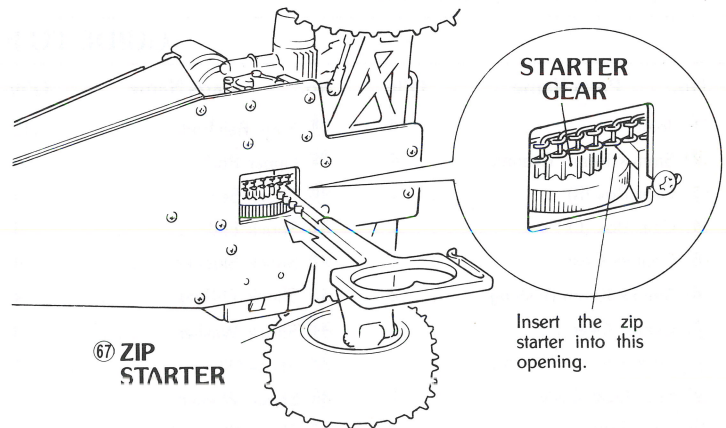

- 7 Then slowly pull the zip starter until you feel some resistance, pause a moment, then quickly pull the zip starter the rest of the way.

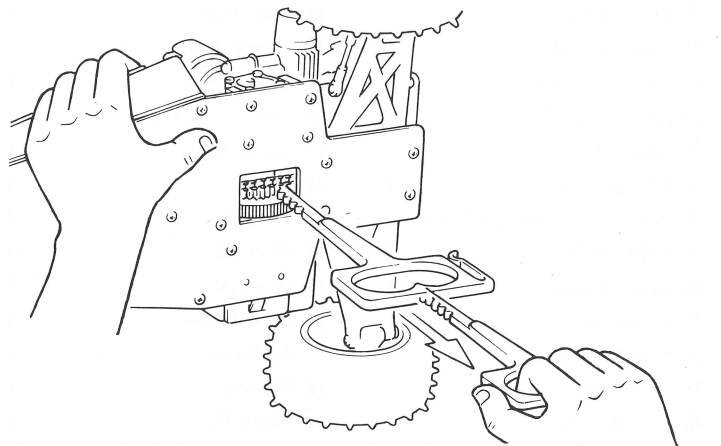

* You may need to do this several times. If you do not hear popping sounds while you are trying, prime the engine and repeat the starting procedure once the engine is started, adjust the needle valve according to the instruction manual that came with the engine.

19 INSTALLATION OF REAR SHOCKS

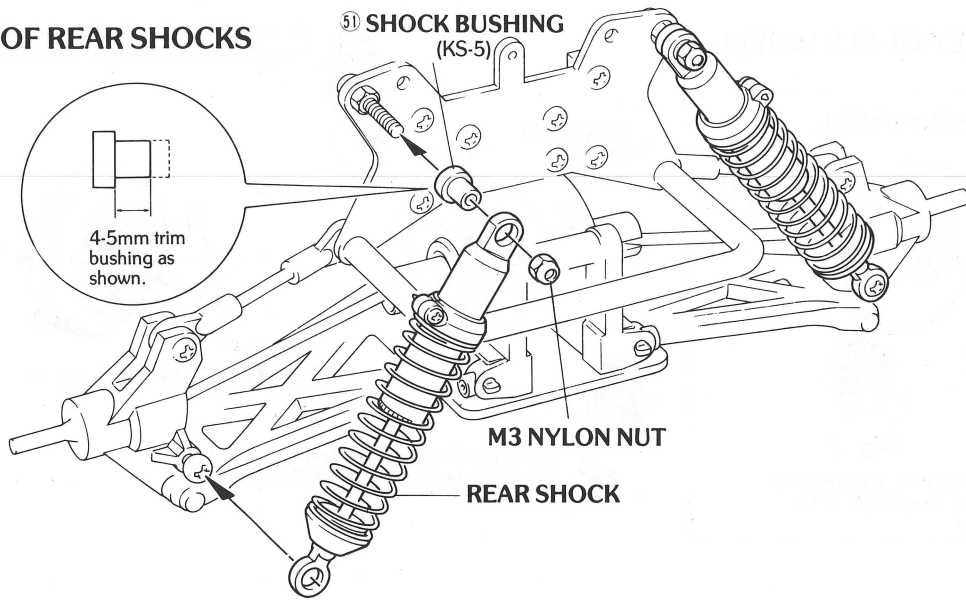

20 MOUNTING THE WHEELS & TIRES

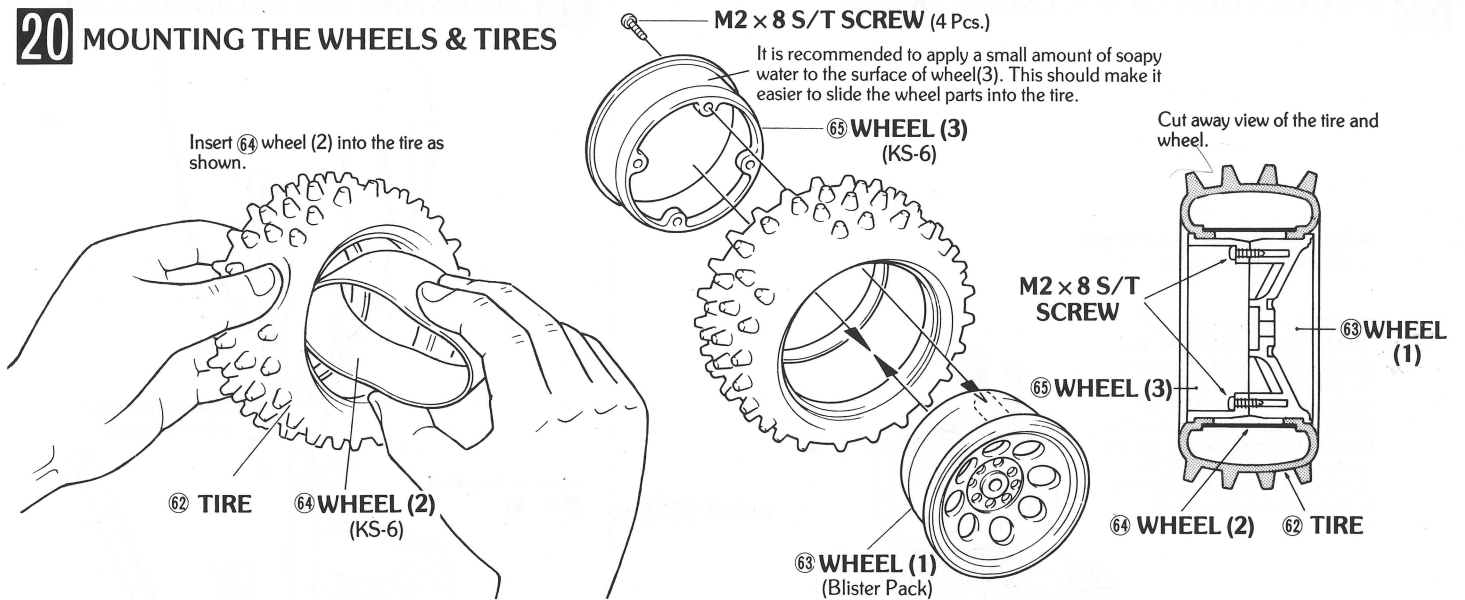

21 INSTALLATION OF TIRES AND SPUR GEAR

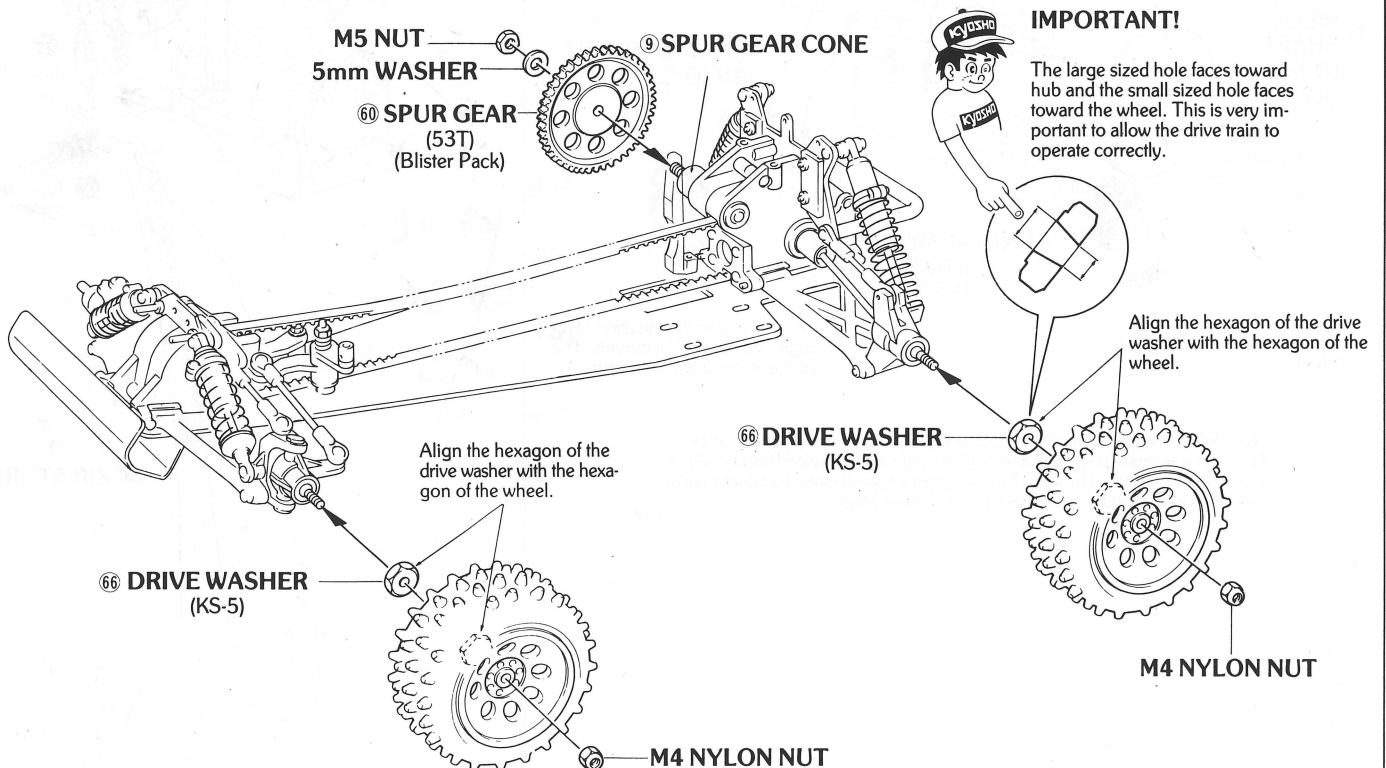

22 ASSEMBLY OF FLY WHEEL

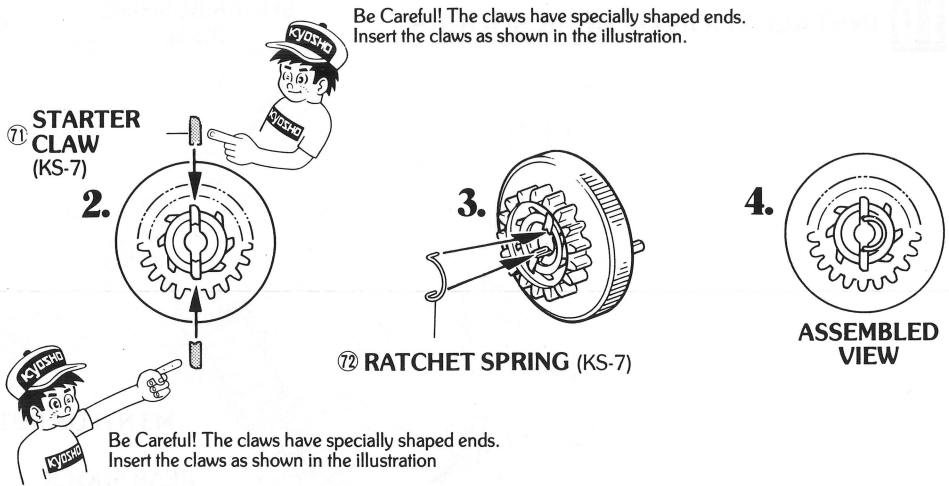
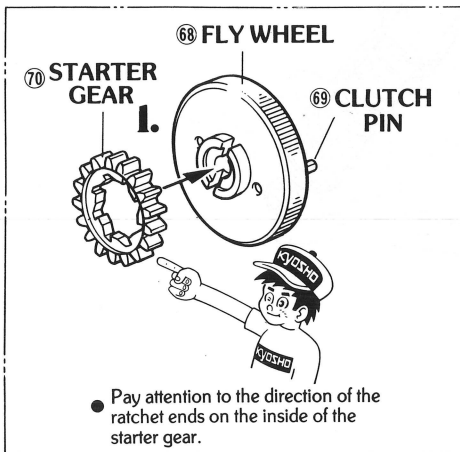

23 INSTALLATION OF O.S. ENGINE MOUNT

- If you are using the OS-CZ Engine use the illustration below

Note! If you are using the O.S. .10 FSR-B, place the washer that comes with your engine between the starter gear and the drive washer of the engine. This will provide adequate clearance for the flywheel and starter gear. If you are using a standard O.S. .10 FSR than a PN-59 Heat Sink will need to be installed on the cylinder head.

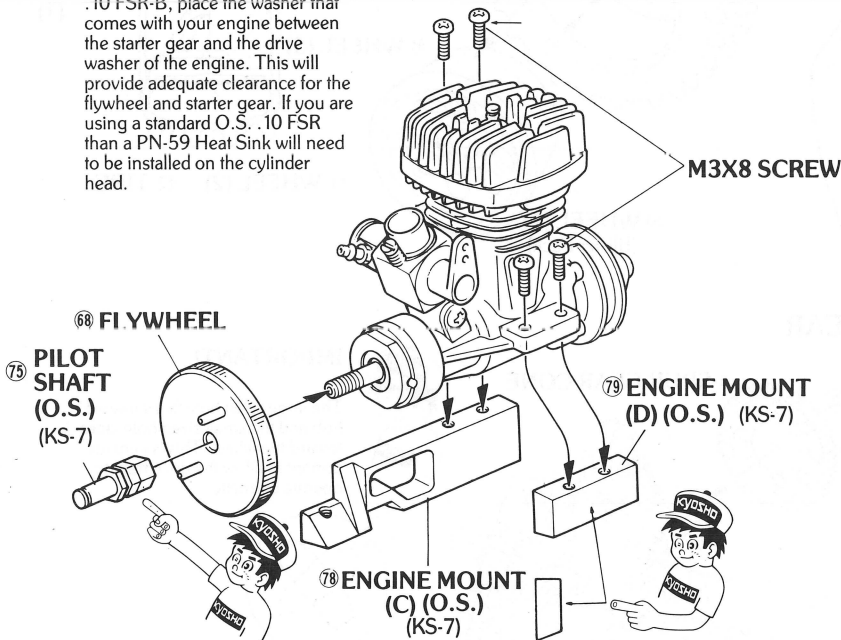

Use the O.S. pilot shaft, the one marked with an engraved strip on it.

Pay attention to the direction of the angles on the engine mounts. The engine is mounted at an angle.

Note: We recommend the O.S. CZ-2 or CZ-R engine for top performance. However a separate pilot shaft and engine mounts are provided for use with a Enya .09-.11 engine. On some Enya engines a special needle adapter may be needed to allow needle adjustment on the Stinger MKII.

24 ADJUSTING THE ENGINE MOUNT

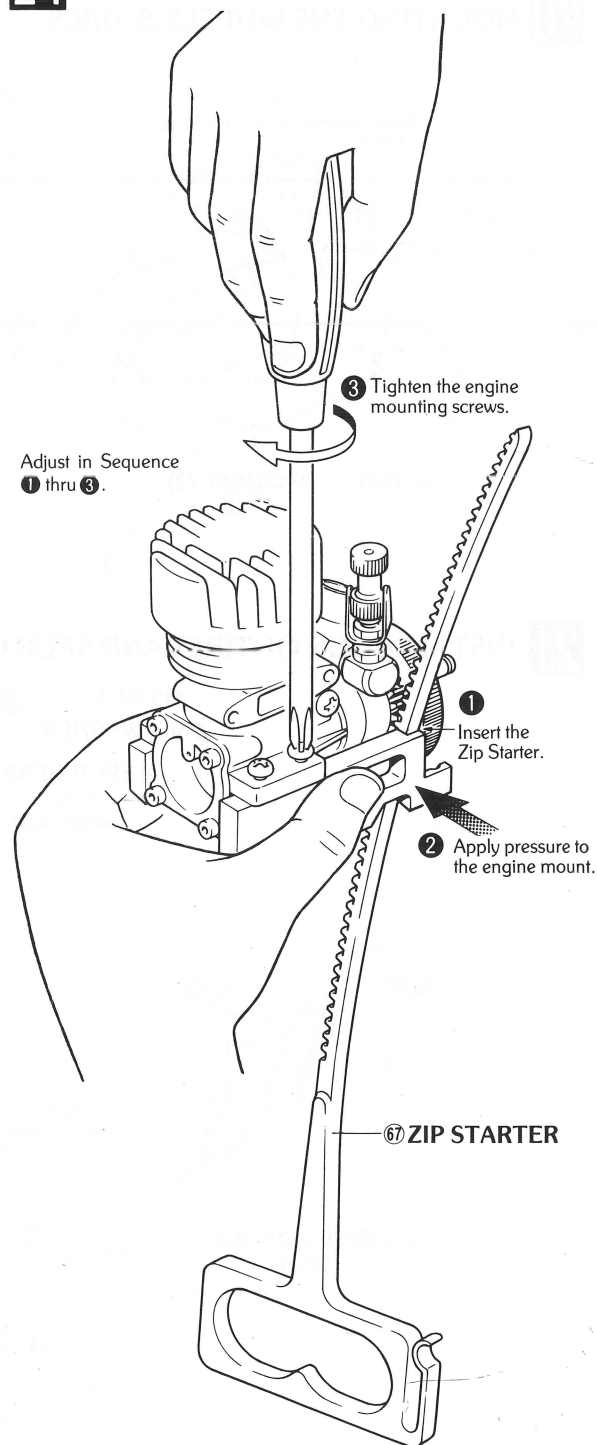

37 INSTALLATION OF RECEIVER AND COVER

Install the edge under the torque rod ball.

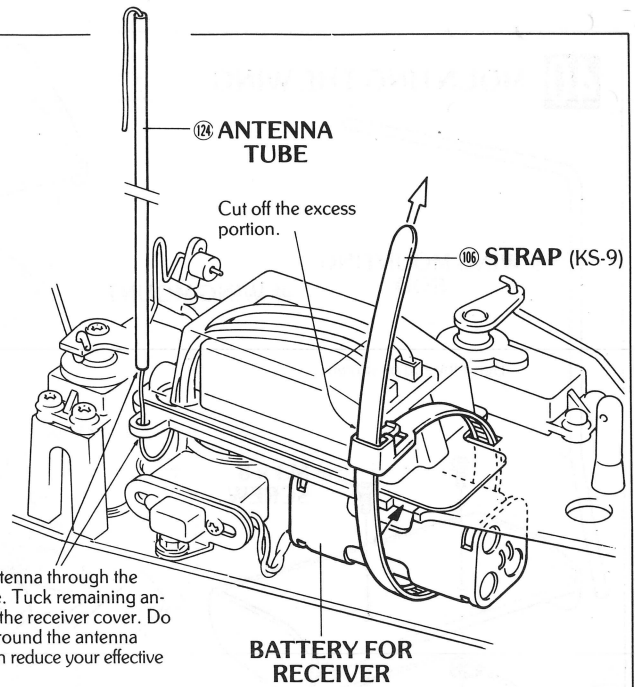
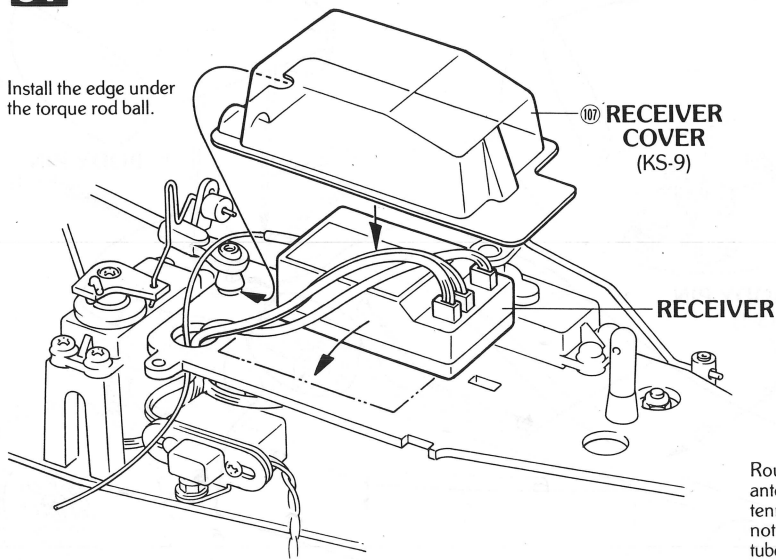

Route the antenna through the antenna tube. Tuck remaining antenna inside the receiver cover. Do not wrap it around the antenna tube. This can reduce your effective range.

38 CUTTING OUT BODY

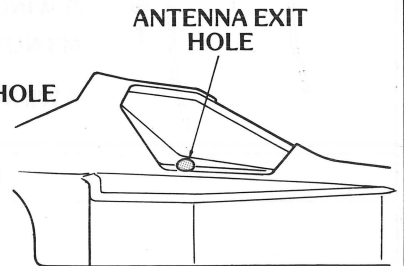
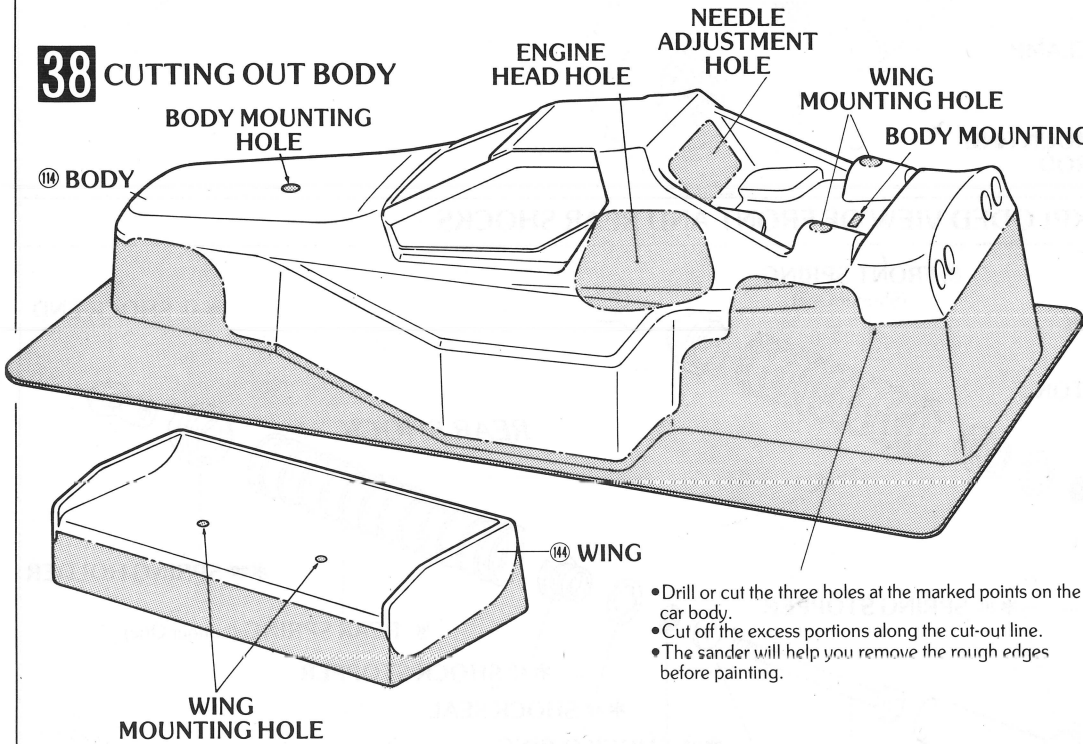

KYOSHO
THE FINEST MADE CONTROL MODELS

These special *Lexan Scissors* make trimming bodies a breeze and the sander comes in handy for finishing the rough edges.

Special Curved Blades

No. 1829

- Drill or cut the three holes at the marked points on the car body.
- Cut off the excess portions along the cut-out line.
- The sander will help you remove the rough edges before painting.

39 PAINTING

First, wash the body to remove any oil or dirt. Rinse thoroughly. Paint the **inside** of the body. You can obtain a color scheme by masking a portion with tape, painting the body, and then removing the tape. Apply the lightest color last.

Use masking tape on windows before painting.

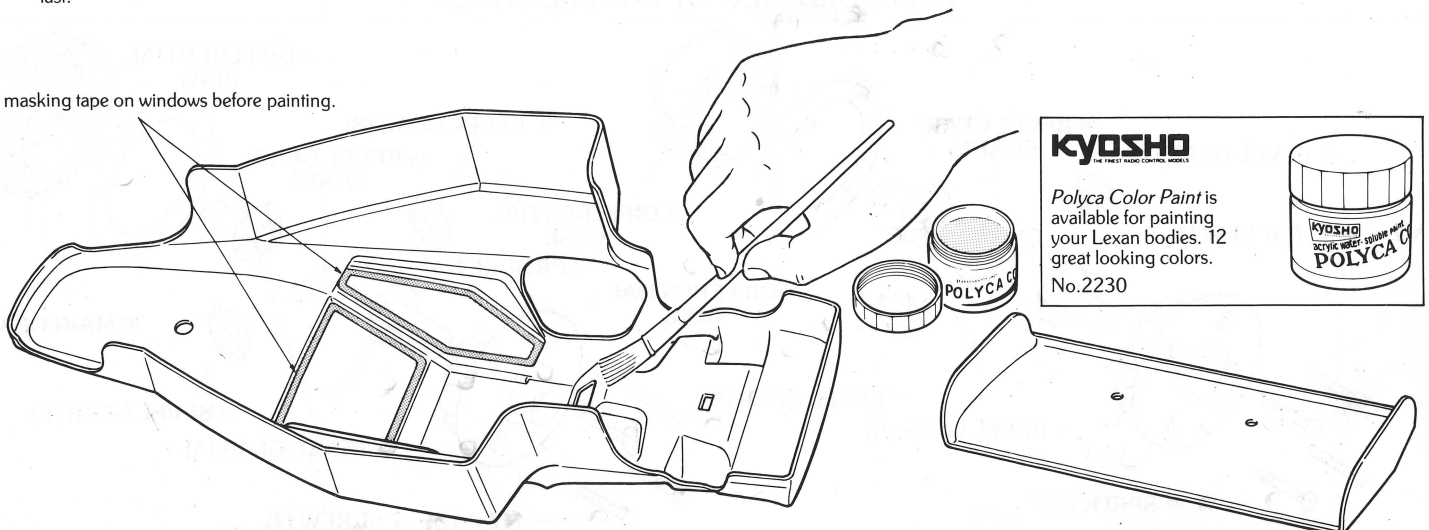

KYOSHO
THE FINEST MADE CONTROL MODELS

Polyca Color Paint is available for painting your Lexan bodies. 12 great looking colors.

No. 2230

34 STEERING CONTROL LINKAGE

A servo horn with a length of at least 16mm from the center to the hole is necessary. Remove the three unnecessary horn arms from the servo horn as they will not be used. Only one arm is necessary for the horn.

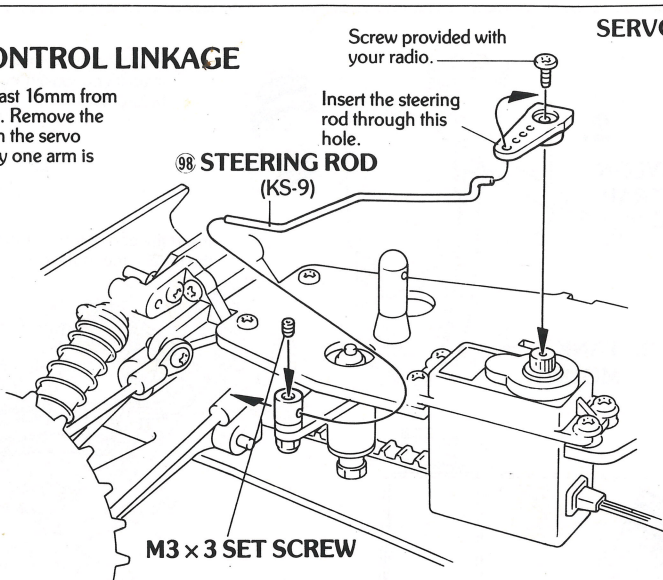
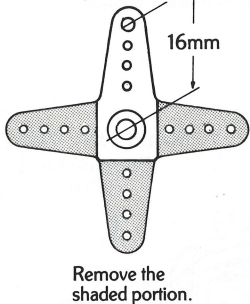

SERVO MOUNTING SURFACE (Radio Plate)

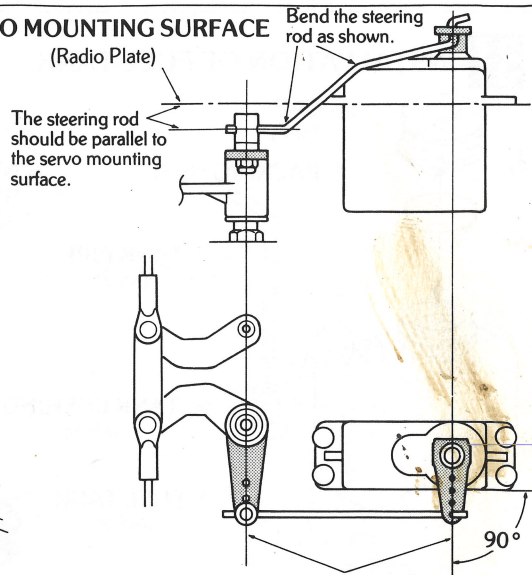

Be certain that the centerline of both arms are parallel and are also 90° to the servo.

35 TORQUE ROD

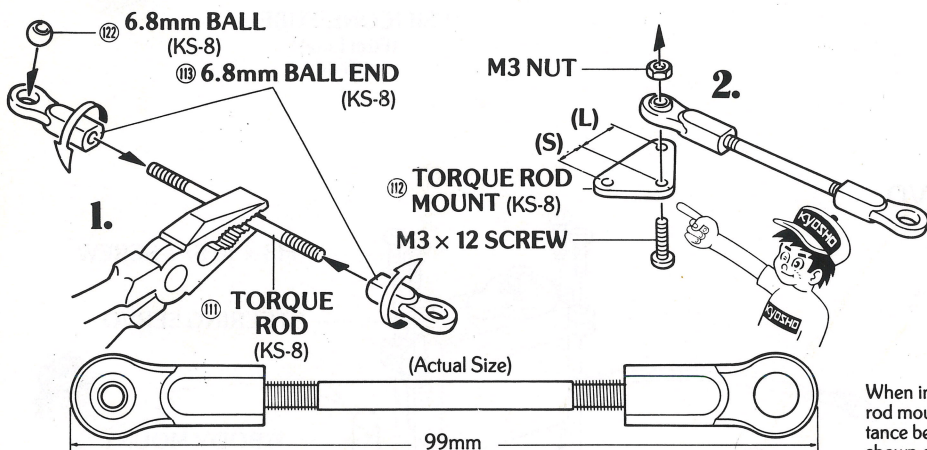

M3 x 10 S/T SCREW

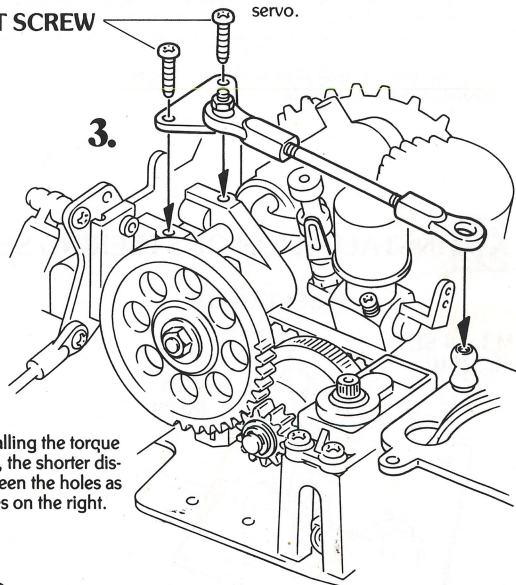

When installing the torque rod mount, the shorter distance between the holes as shown goes on the right.

36 INSTALLATION OF THE THROTTLE LINKAGE

A servo horn with a length of at least 14mm from the center to the hole is necessary. Remove the two unnecessary horn arms from the servo horn as they will not be used. Only two arms are necessary for the horn.

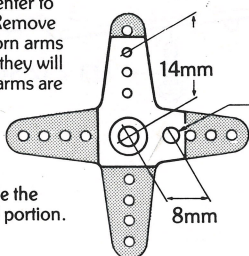

This hole may need to be enlarged slightly to allow the brake rod to fit.

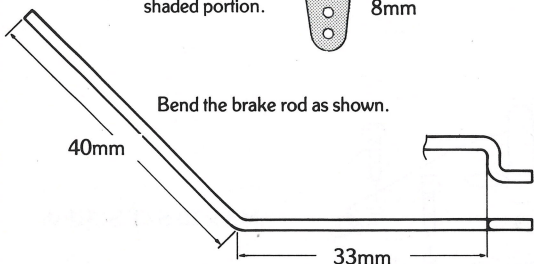

98 BRAKE ROD (KS-9)

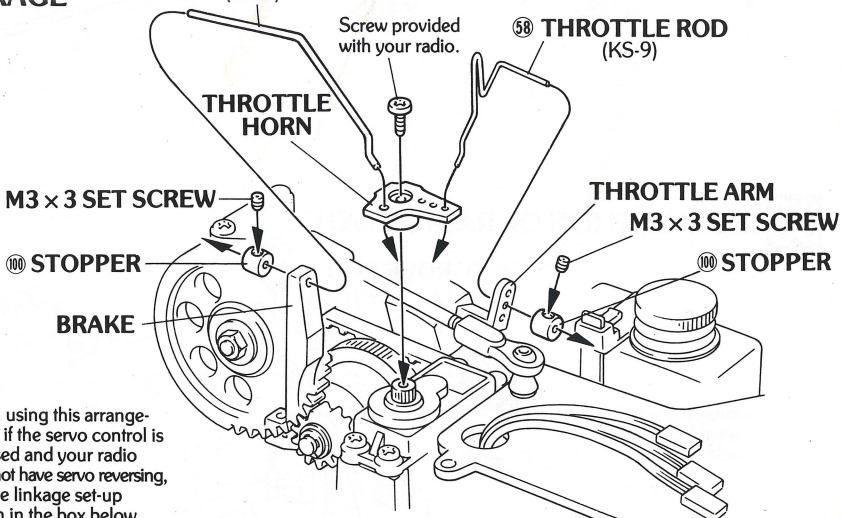

When using this arrangement, if the servo control is reversed and your radio does not have servo reversing, use the linkage set-up shown in the box below.

(HIGH THROTTLE) (LOW THROTTLE)

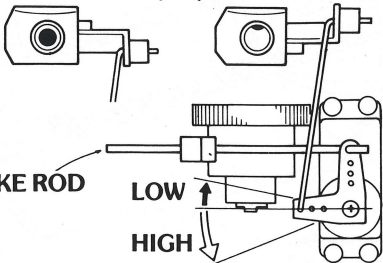

(HIGH THROTTLE) (LOW THROTTLE)

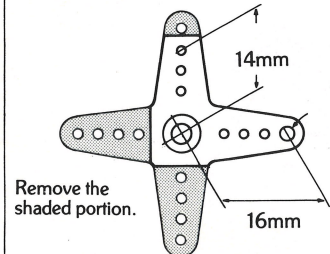
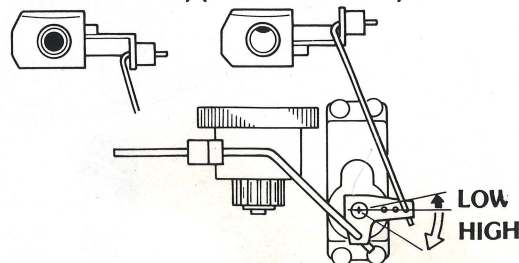

25 INSTALLATION OF MUFFLER

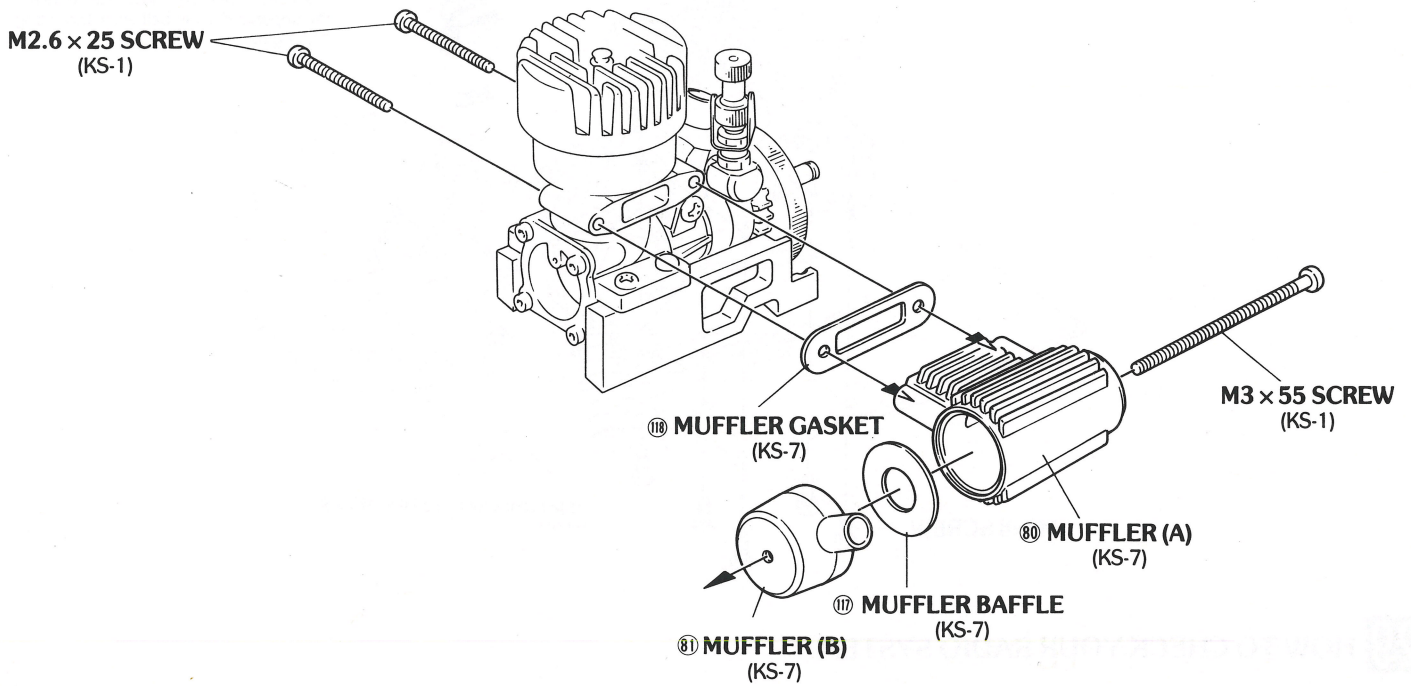

26 INSTALLATION OF CLUTCH

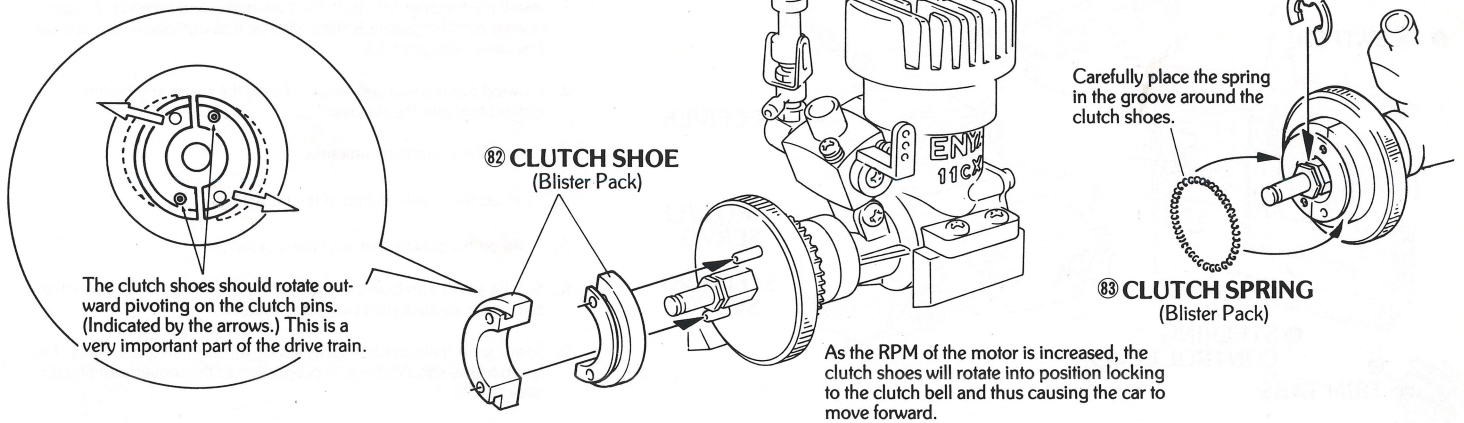

27 INSTALLATION OF CLUTCH BELL AND AIR FILTER

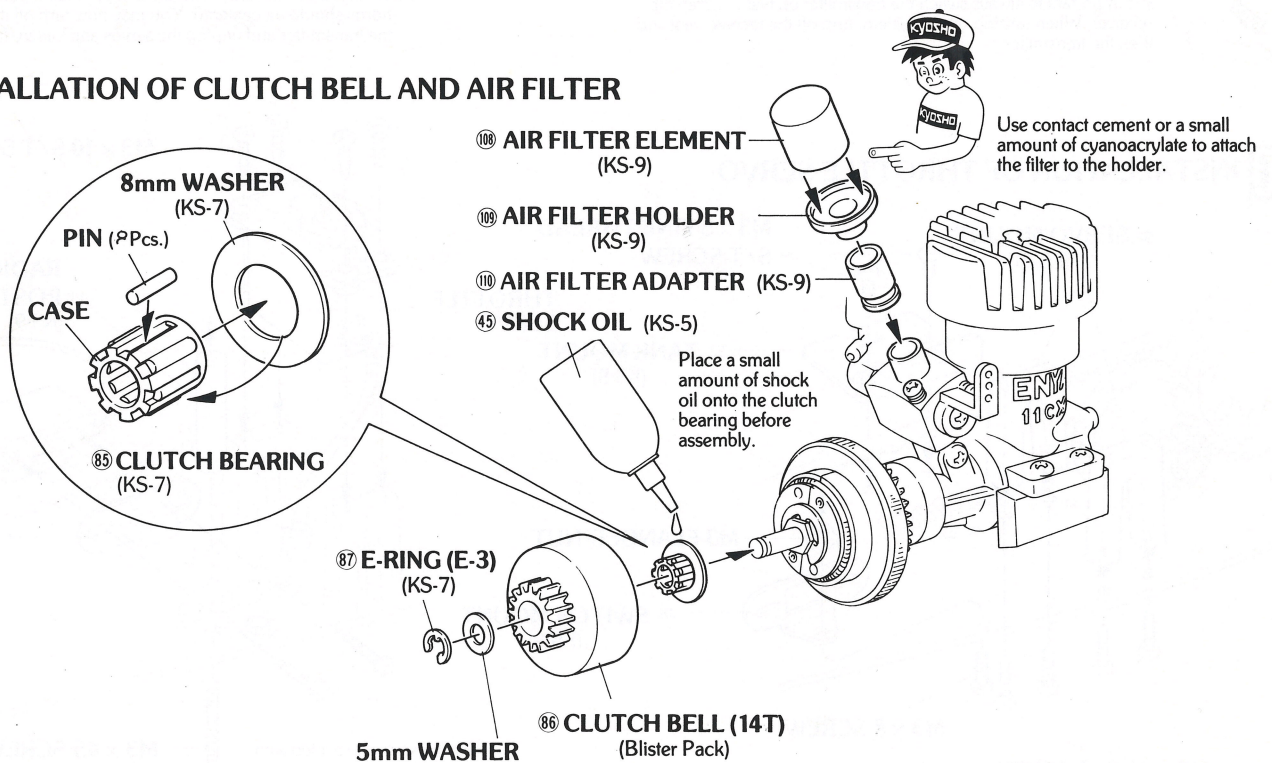

7 INSTALLATION OF GEAR BOX

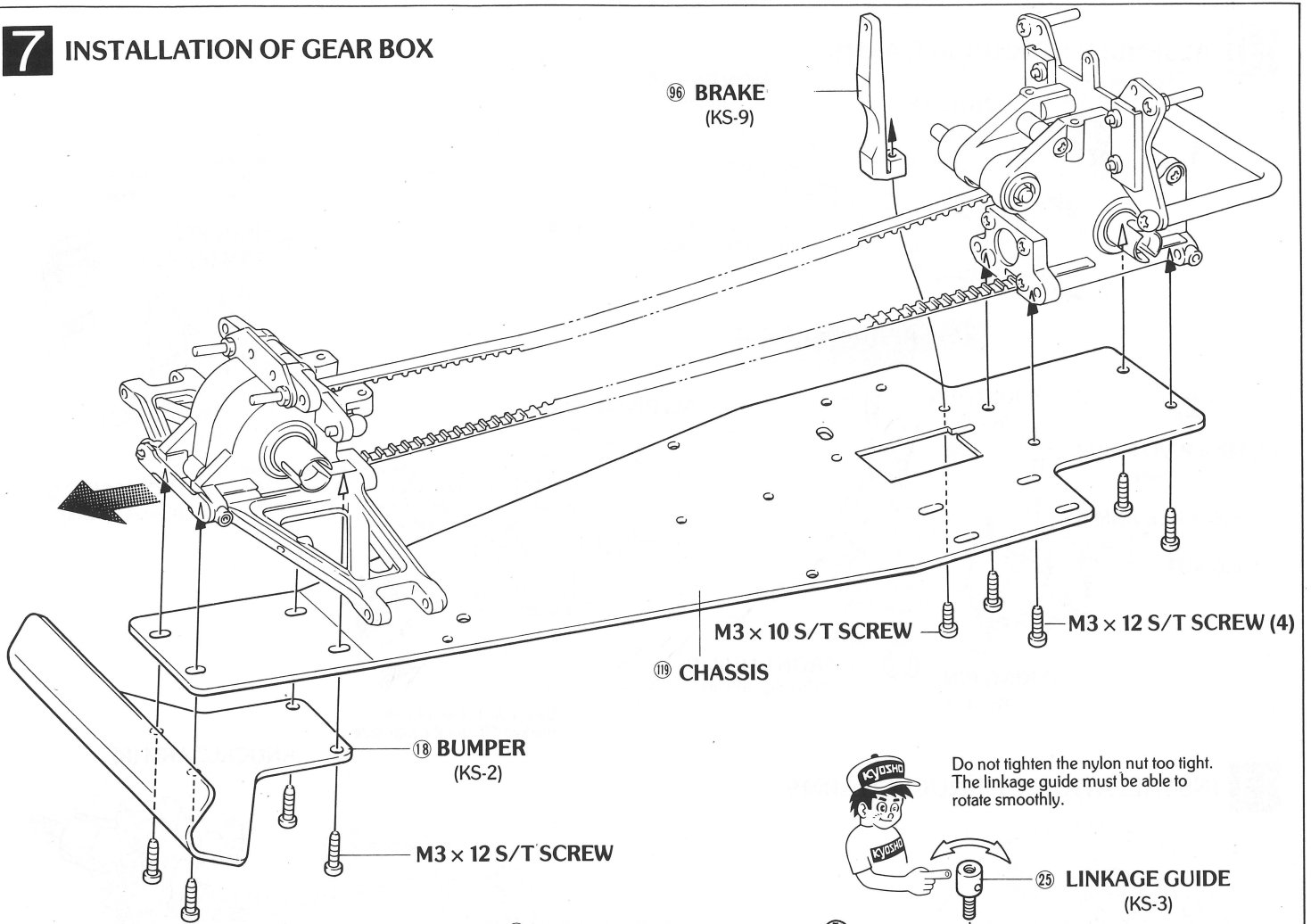

8 ASSEMBLY OF SERVO SAVER

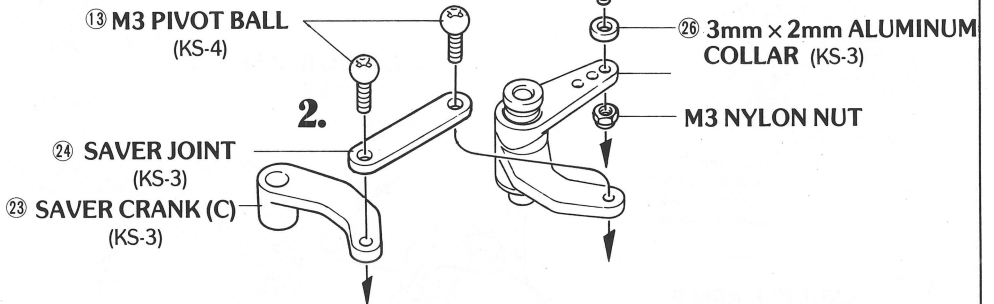
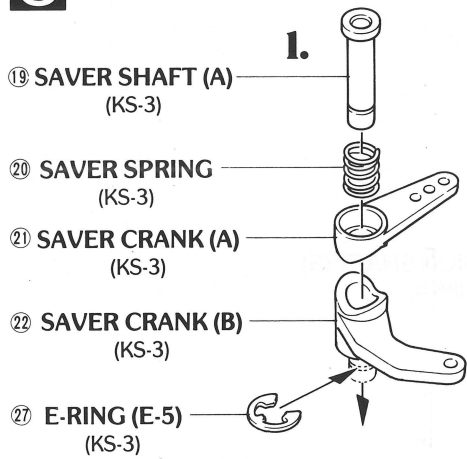

9 INSTALLATION OF SERVO SAVER

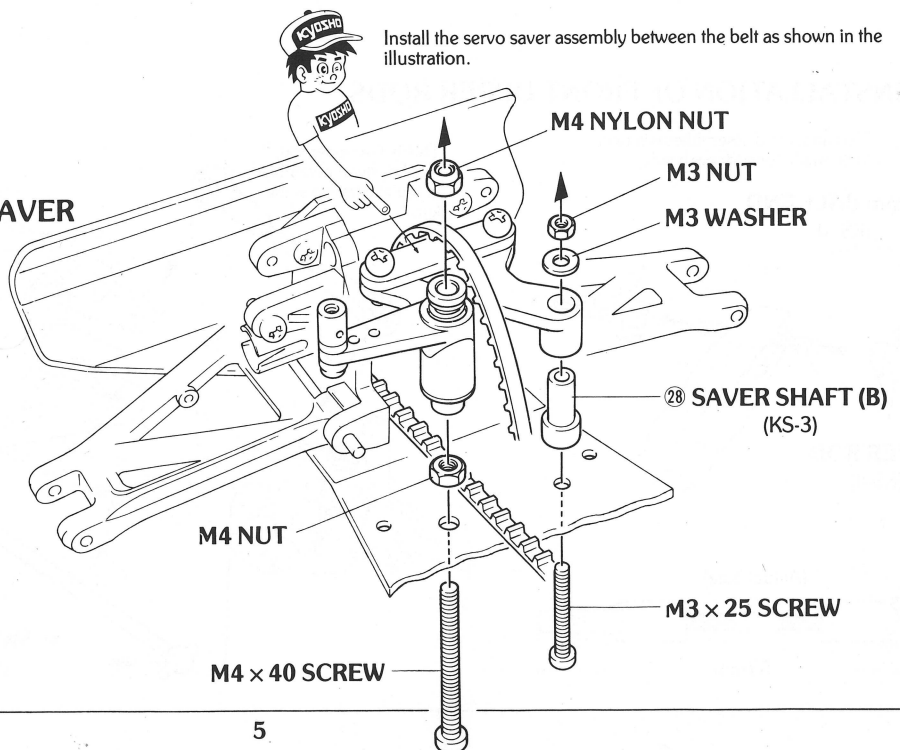

LIST OF BAGGED PARTS (1)

< BLISTER PACK >

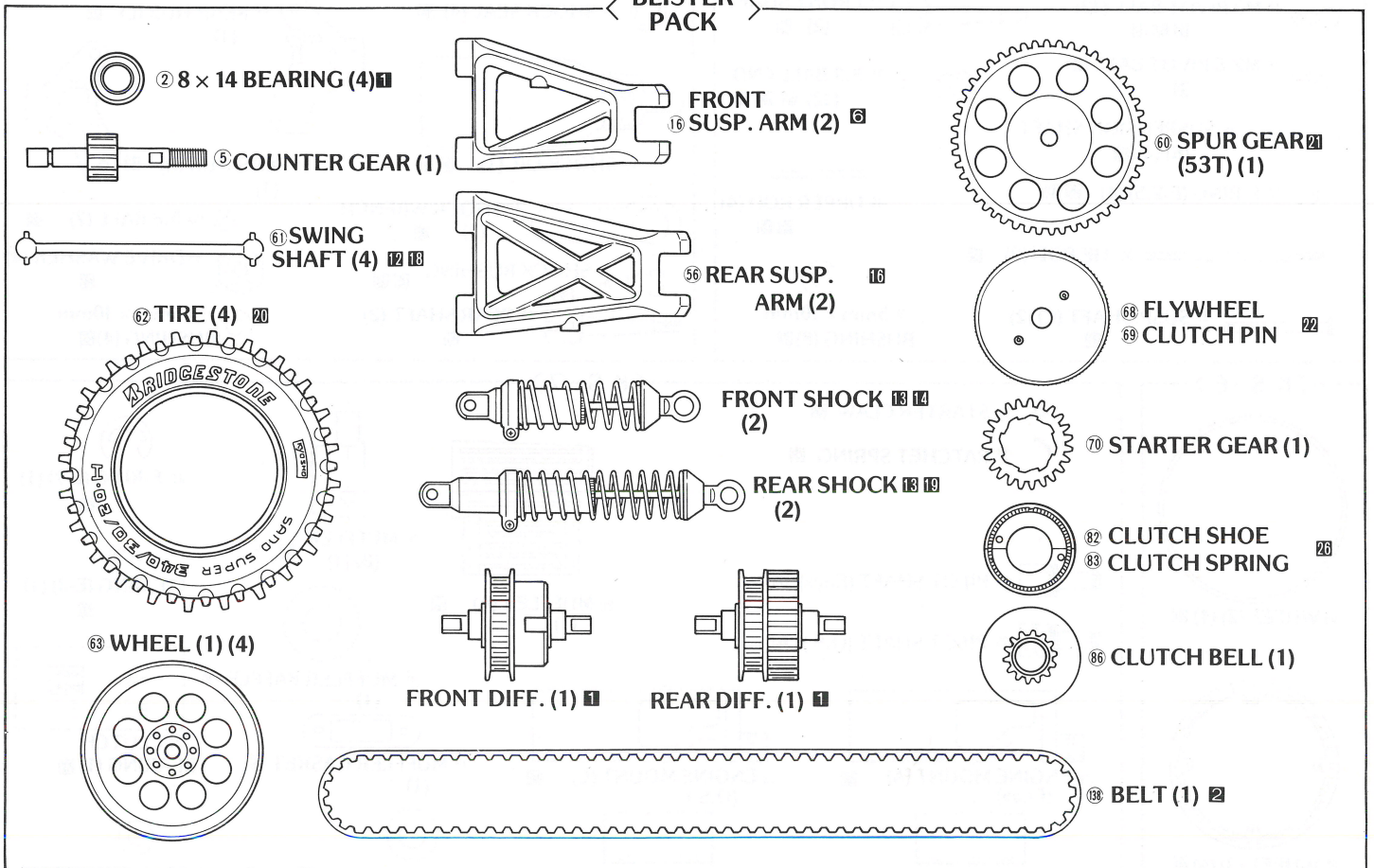

< K S - 1 >

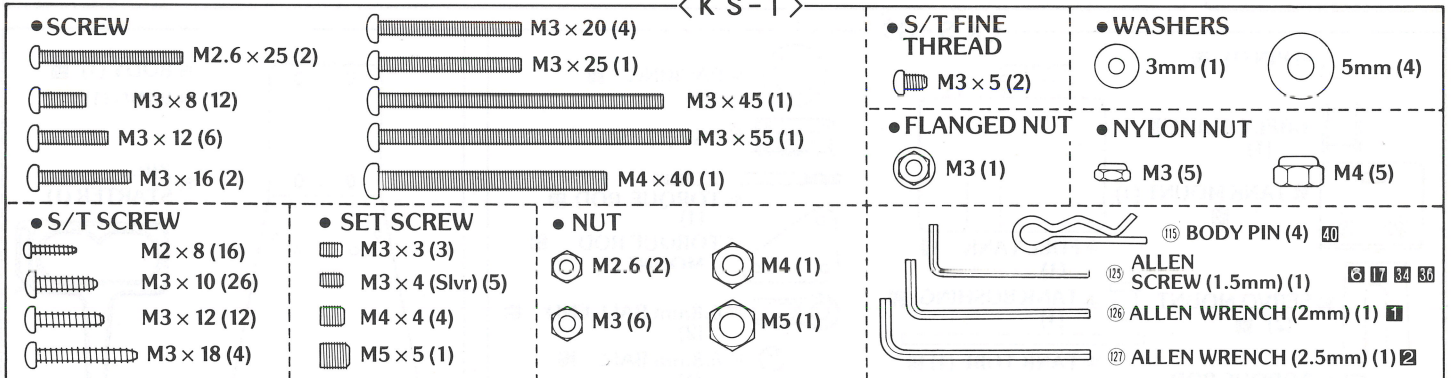

< K S - 2 >

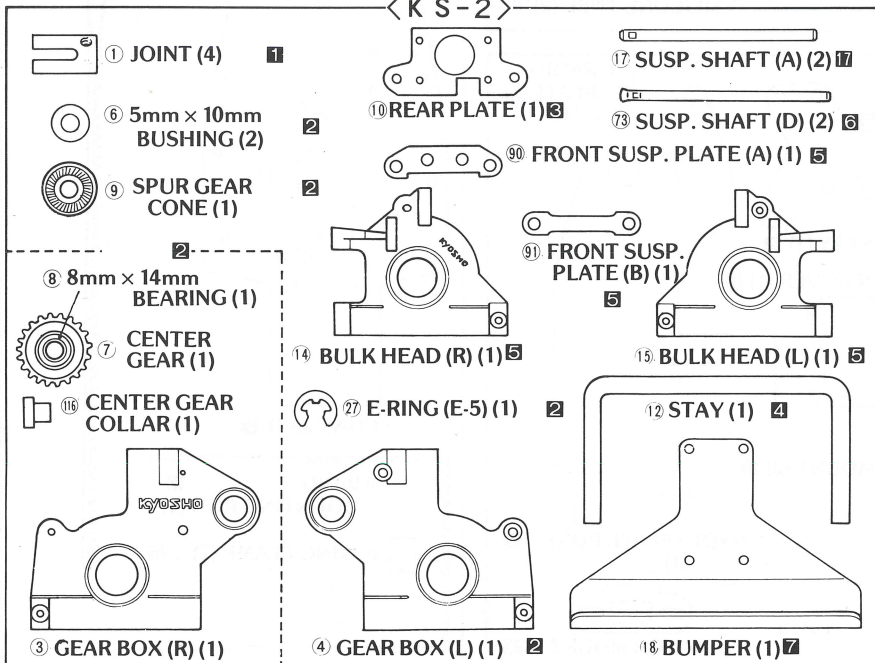

< K S - 3 >

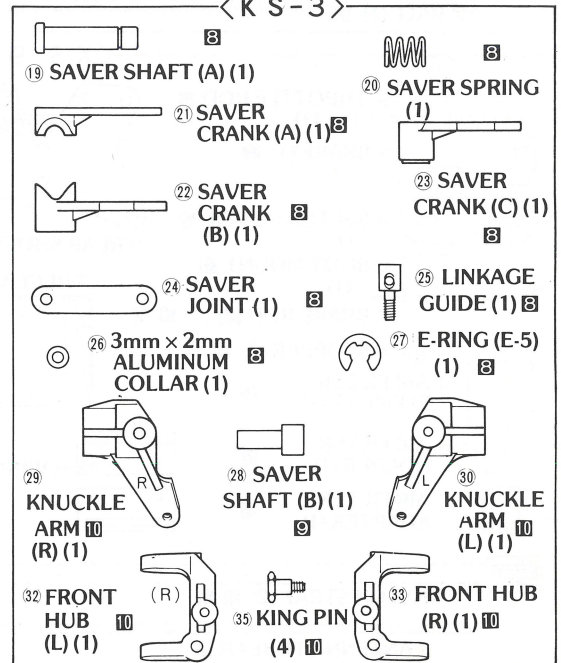

LIST OF BAGGED PARTS (2)

< K S - 4 >

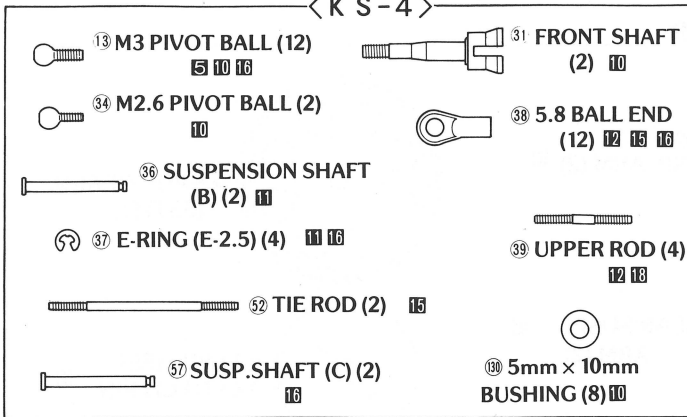

< K S - 5 >

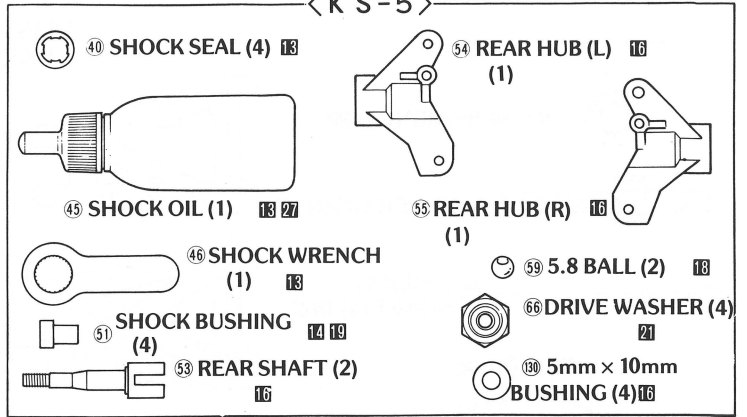

< K S - 6 >

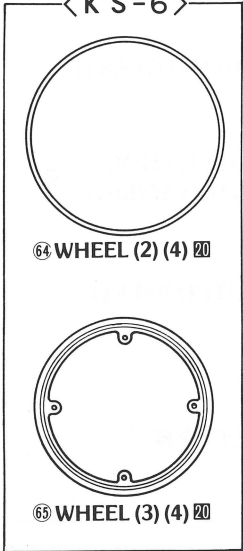

< K S - 7 >

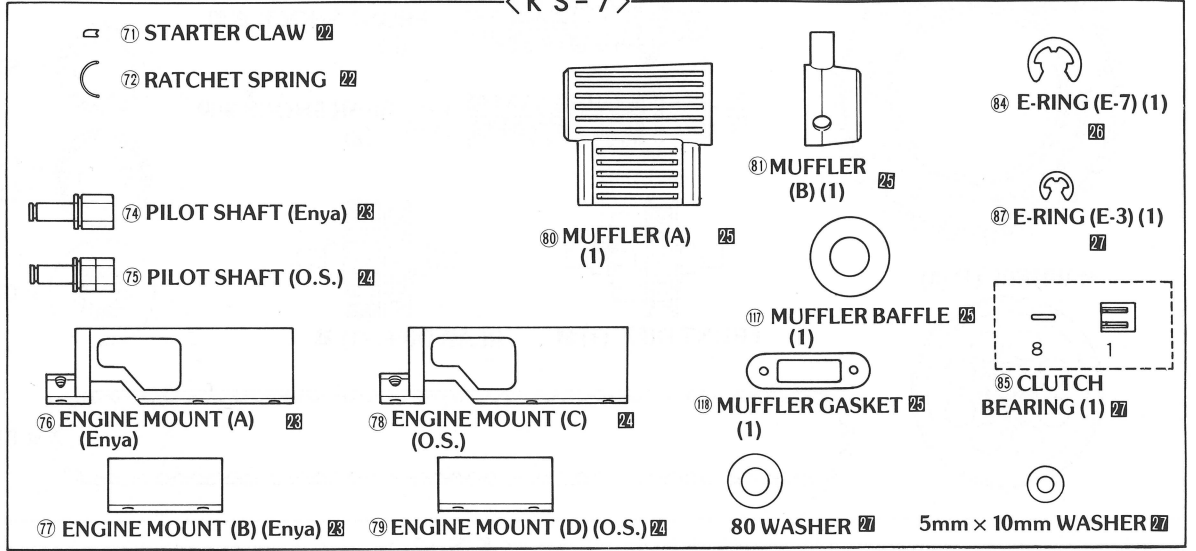

< K S - 8 >

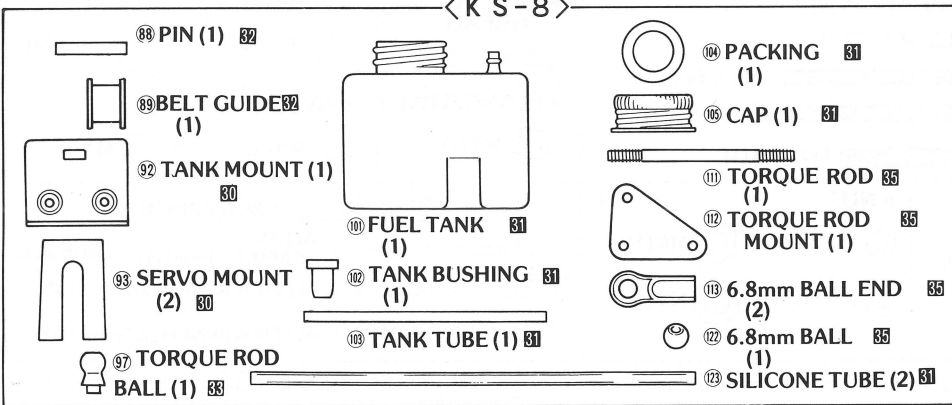

< K S - 9 >

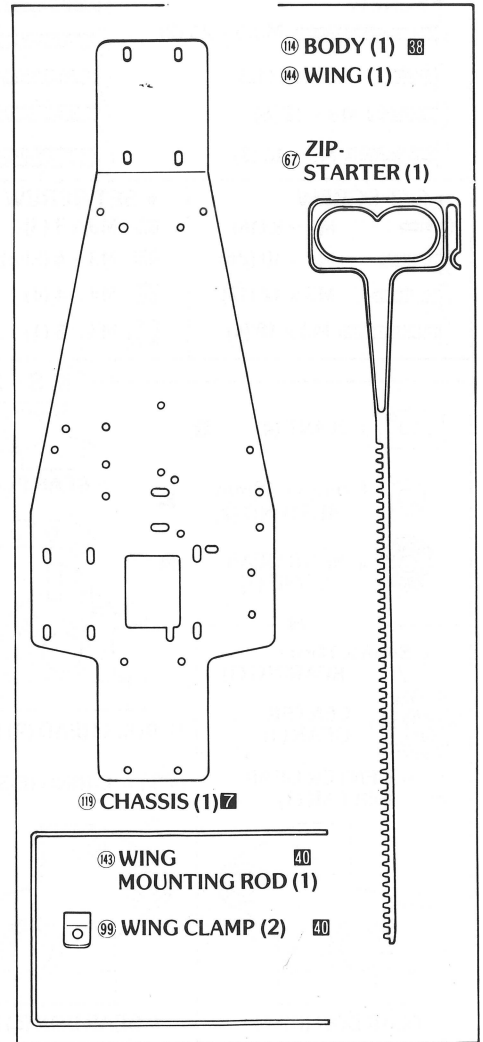
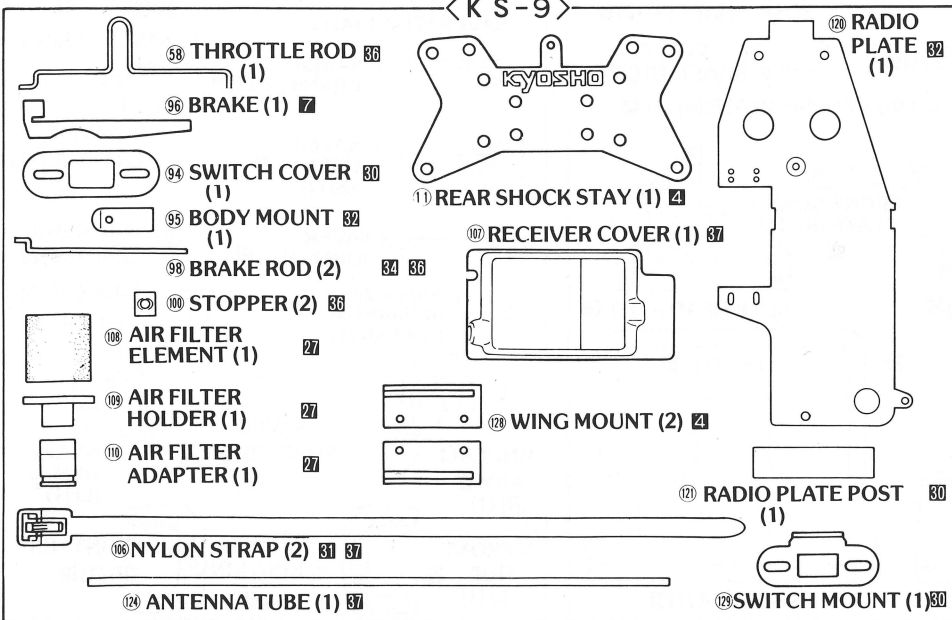

PURCHASING PARTS FOR YOUR KIT

You can purchase replacement and optional parts for your kit. All of the parts identified by key numbers (see Page 17 for a complete list) are usually not available singularly, but we offer these parts in convenient parts "packs" which can be purchased separately. To figure out which parts pack you need, find the key number for that part within the

manual. Then consult our parts pack guide, below. When referring to the parts you need, always use the parts pack number. For instance, if you need a center gear (Key #7) ask your dealer for Kyosho Parts Pack SG-2 (Gear Set).

Parts Pack #	Description	Includes These Key #s
OT-004	KING PIN	35 X 4
OT-005	JOINT	1 X 2
OT-006	SWING SHAFT	61 X 2
OT-013	SUSP. ARM SET	16 56 X 2
OT-016	KNUCKLE ARM SET	29 30 X 1
OT-017	FRONT SHAFT	31 X 2
OT-018	REAR SHAFT	53 X 2
OT-019	DRIVE WASHER	66 X 4
OT-028	DIFF. GEAR SET	136 X 2 134 135 X 4
OT-031	M3 PIVOT BALL	13 X 10
OT-032	5.8mm BALL	59 X 10
OT-035	UPPER ROD	39 X 4 38 X 8
OT-036	M2.6 PIVOT BALL	34 X 10
OT-039	E-RING (E-2.5)	37 X 10
OT-043	REAR SHOCK	46 X 1 40 41 42 43 44 48 50 51 59 140 141 142 X 2
OT-045	REAR HUB	54 55 X 2
OT-047	FRONT HUB	32 33 X 1
OT-066	LOW PROFILE TIRE	62 X 2
OT-067	LOW PROFILE WHEEL	63 64 65 X 2
AB-11	MUFFLER	80 81 107 108 X 1
AB-12	AIR FILTER	100 109 110 X 1
AB-13	PILOT SHAFT (ENYA)	74 84 87 X 1
AB-14	PILOT SHAFT (O.S.)	75 84 87 X 1
AB-15	CLUTCH SHOE	82 X 2
AB-16	CLUTCH BELL	86 X 1
AB-17	CLUTCH SPRING	83 X 4
AB-27	FLY WHEEL	68 X 1 69 X 2
AB-28	STARTER GEAR SET	70 72 X 1 71 X 2
AB-30	FRONT SHOCK	46 X 1 40 41 42 43 44 47 49 51 59 139 141 142 X 2
EF-022	HOOK PIN	115 X 5
EF-039	NiCd STRAP	106 X 6
MB-63	ZIP STARTER	67 X 4
LD-70	CLUTCH BEARING	85 X 1
SC-89	TIE ROD	34 52 X 2 38 X 4
SD-79	ANTENNA PIPE	124 X 5
FM-209	E-RING (E-5)	27 X 5
1901	5mm x 10mm BEARING	8 X 2

Parts Pack #	Description	Includes These Key #s
1911	8mm x 14mm BEARING	2 X 2
SG-01	GEAR BOX SET	3 4 10 14 15 X 1
SG-02	GEAR SET	5 7 9 116 X 1
SG-04	SUSP. SHAFT SET	17 36 57 73 X 2
SG-05	LINKAGE SET	25 26 58 X 1 98 104 X 2
SG-06	ENGINE MOUNT (ENYA)	76 77 X 2
SG-07	ENGINE MOUNT (O.S.CZ1)	78 79 X 2
SG-09	BUMPER SET	12 18 X 1
SG-10	MOUNT, COVER SET	92 94 107 X 1
SG-12	SERVO SAVER SET	19 20 21 22 23 24 28 X 1
SG-13	FUEL TANK SET	101 102 103 104 105 123 X 1
SG-14	METAL SET	6 X 1 30 X 8
SG-18	BODY	114 X 1
SG-19	CHASSIS	119 X 1
SG-21	PLASTIC GEAR SET	131 132 133 137 X 1
SG-24	BELT	139 X 1
SG-25	SPROCKET SET	131 137 X 1 132 133 X 2
SG-26	RADIO PLATE SET	88 89 95 96 120 X 1 93 124 X 2
SG-27	TORQUE ROD SET	97 111 112 121 122 X 1 119 X 2
SG-28	STAY SET	11 90 91 129 X 1
SG-29	SPUR GEAR	60 X 1
SG-30	SCREW SET	
SG-31	WING SET	143 144 X 1 99 X 2
SG-32	DECAL	145 X 1

OPTIONAL PARTS

W-5031	LOW PROFILE TIRE (HARD)	HARD SURFACES
W-5032	LOW PROFILE TIRE (SOFT)	SOFT SURFACES
FM-082	CLUTCH BELL (11T)	
SD-53	CLUTCH BELL (12T)	
SD-54	CLUTCH BELL (13T)	
1951	SHOCK OIL SET	1 SET SOFT, MEDIUM, HARD
1952	DIFF. OIL	
W-5001	GOLD SHOCK (S)	
W-5002	GOLD SHOCK (L)	
W-5003	PLATINUM SHOCK (S)	ADJUSTABLE PRESSURE
W-5004	PLATINUM SHOCK (L)	ADJUSTABLE PRESSURE

28 MOUNTING OF ENGINE

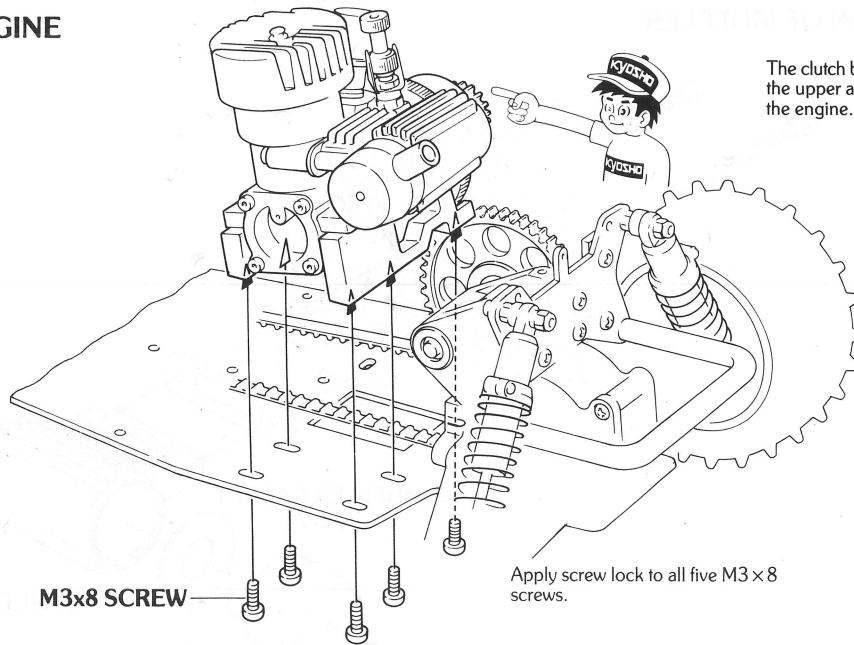

The clutch bell should be routed between the upper and lower belt while mounting the engine.

29 HOW TO CHECK YOUR RADIO SYSTEM

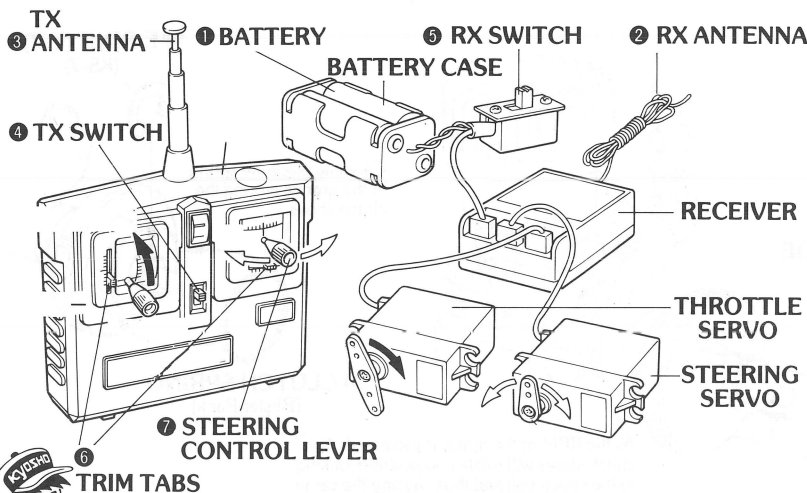

Follow steps 1-8.

1. Install the batteries into both the transmitter and receiver. If your radio is a rechargeable system, charge it as outlined in the manual that came with your set.
2. Unwind the receiver antenna and plug the servo and battery connectors into the receiver.
3. Extend the transmitter antenna.
4. Turn on the power switch of the transmitter.
5. Turn on the power switch of the receiver.
6. Set the small trim levers to the center position and make sure that both main control sticks are also centered.
7. Move both main control sticks slowly through their full travel. The servo horns should move in proportion to the movement of your sticks.
8. When trim levers and sticks are at their neutral positions, the servo horns should be centered. You may now turn off the receiver, then the transmitter and unplug the servos and battery from the receiver.



It is important to always switch the transmitter on first . . . then the receiver. When turning off the system, turn off the receiver first and then the transmitter.



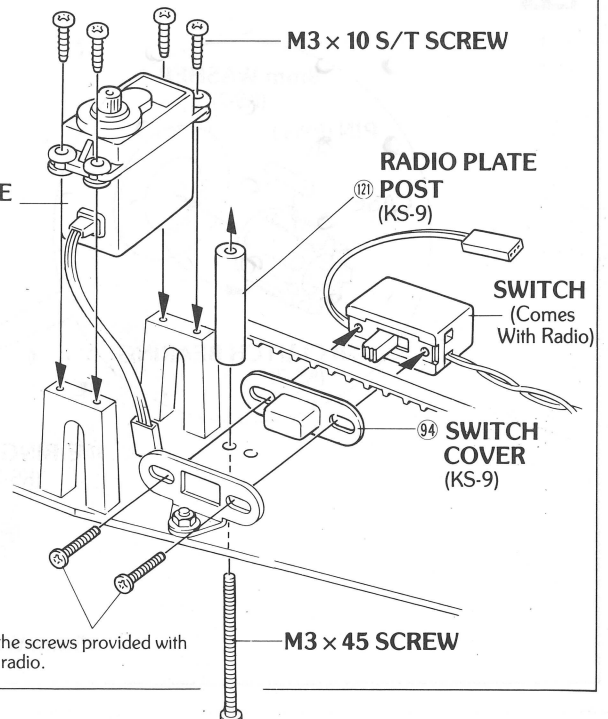
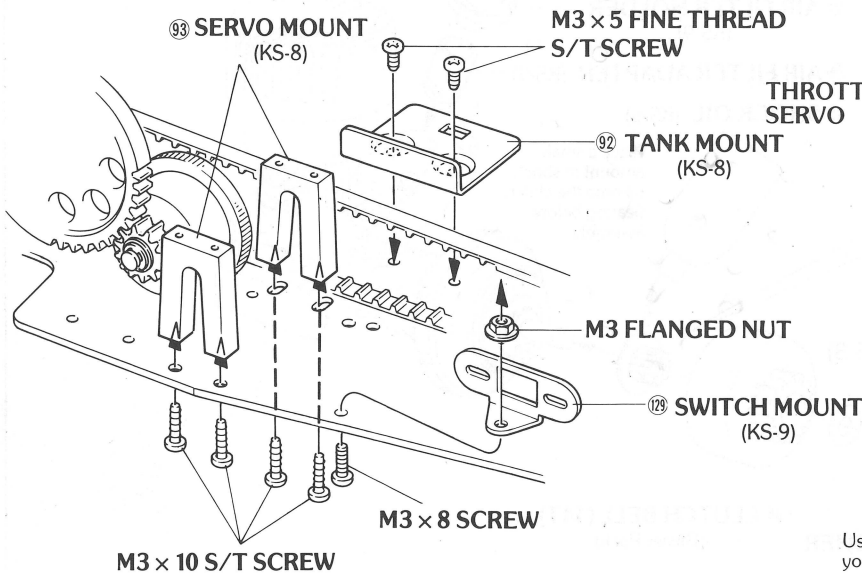

30 INSTALLATION OF THROTTLE SERVO



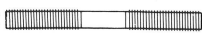

Use the screws provided with your radio.

SMALL PARTS USED IN EACH ASSEMBLY STEP

18 INSTALLATION OF REAR UPPER RODS

- M3 x 12 SCREW2 
- 38 5.8mm BALL END . .4 
- 39 UPPER ROD2 
- 59 5.8 BALL2 



19 INSTALLATION OF REAR SHOCKS

- M3 NYLON NUT2 
- 51 SHOCK BUSHING . .2 



20 MOUNTING THE WHEELS AND TIRES

- M2 x 8 S/T SCREW . .16 

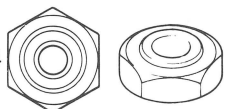
21 INSTALLATION OF TIRES AND SPUR GEAR

- M4 NYLON NUT4 
- M5 NUT1 
- 5mm WASHER1 
- 66 DRIVE WASHER . .4 

22 ASSEMBLY OF FLY WHEEL

- 71 STARTER CLAW . .2 
- 72 RATCHET SPRING .1 

23 INSTALLATION OF O.S. ENGINE MOUNT

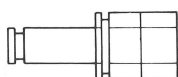
- M3 x 8 SCREW4 
- 75 PILOT SHAFT (O.S.) . .1 

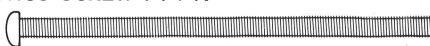

25 INSTALLATION OF MUFFLER

- M2.6 x 25 SCREW . . .2 
- M3 x 55 SCREW1 

26 INSTALLATION OF CLUTCH

- 84 E-RING (E-7)1 

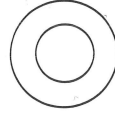
27 INSTALLATION OF CLUTCH BELL AND AIR FILTER

- 5mm x 10mm WASHER . . .1 
- 8mm WASHER1 
- 85 CLUTCH BEARING8 

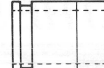



- 100 AIR FILTER ADAPTER . . .1 

- 87 E-RING (E-3)1 

28 MOUNTING OF ENGINE

- M3 x 8 SCREW5 

30 INSTALLATION OF THROTTLE SERVO

- M3 x 5 FINE THREAD S/T SCREW2 
- M3 x 8 SCREW1 
- M3 x 10 S/T SCREW . .8 
- M3 x 45 SCREW1 
- M3 FLANGED NUT . .1 





- 94 SWITCH COVER1 

- 121 RADIO PLATE POST1 

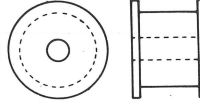

31 INSTALLATION OF FUEL TANK

- 102 TANK BUSHING1 

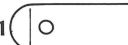
32 INSTALLATION OF STEERING SERVO

- M3 x 4 SET SCREW . . .1 
- M3 x 10 S/T SCREW . .4 
- M3 x 12 SCREW1 
- 89 BELT GUIDE1 
- 90 PIN1 
- 95 BODY MOUNT1 

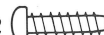

33 INSTALLATION OF RADIO PLATE

- M3 x 10 S/T SCREW . .2 
- 97 TORQUE ROD BALL .1 

34 STEERING CONTROL LINKAGE

- M3 x 3 SET SCREW . . .1 

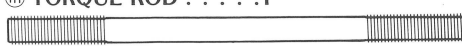

35 TORQUE ROD

- M3 x 10 S/T SCREW . .2 
- M3 x 12 SCREW1 
- M3 NUT1 
- 111 TORQUE ROD1 





- 113 6.8 BALL END2 

- 122 6.8 BALL1 

36 INSTALLATION OF THROTTLE LINKAGE

- M3 x 3 SET SCREW . . .2 
- 100 STOPPER2 

40 MOUNTING THE WING

- M3 x 8 SCREW2 
- M3 NUT2 
- 115 BODY PIN2 
- 99 WING CLAMP2 

31 INSTALLATION OF FUEL TANK

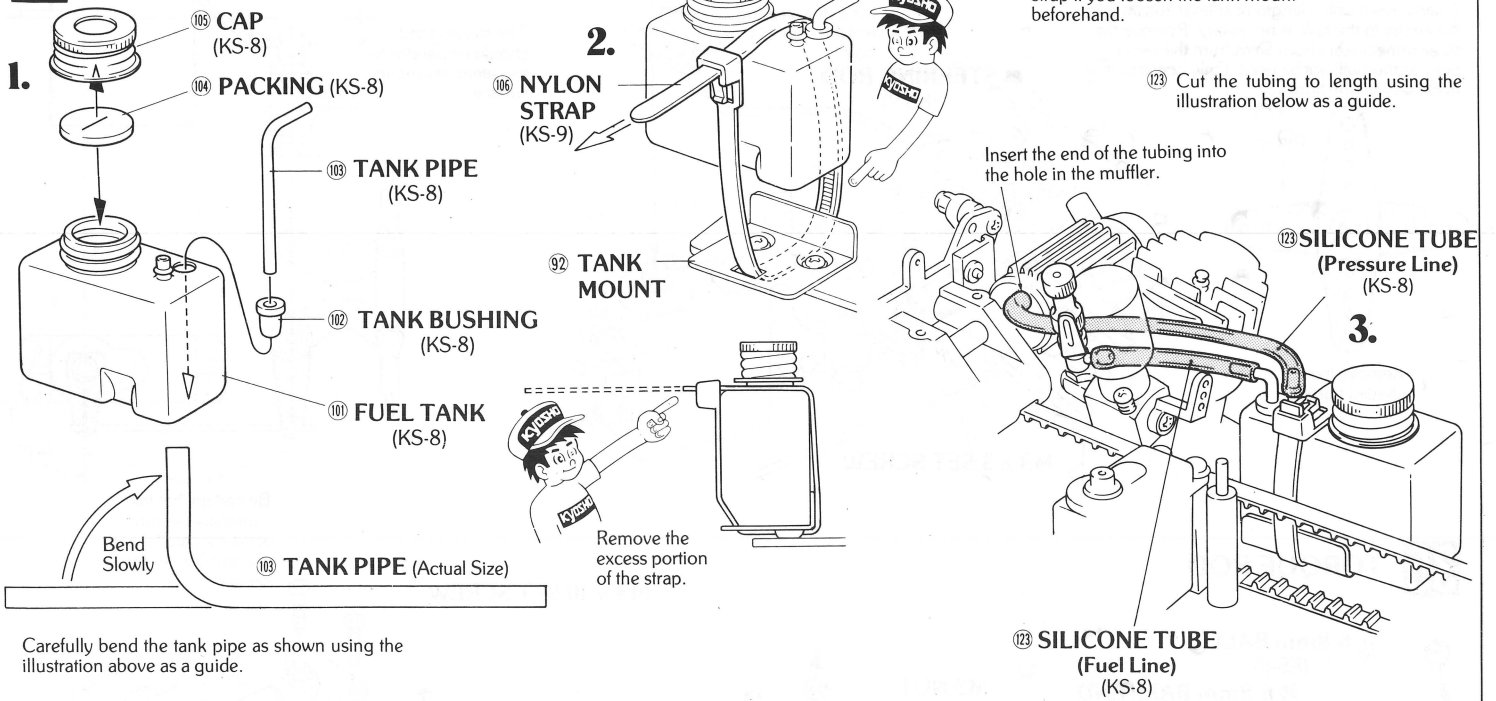

32 INSTALLATION OF STEERING SERVO

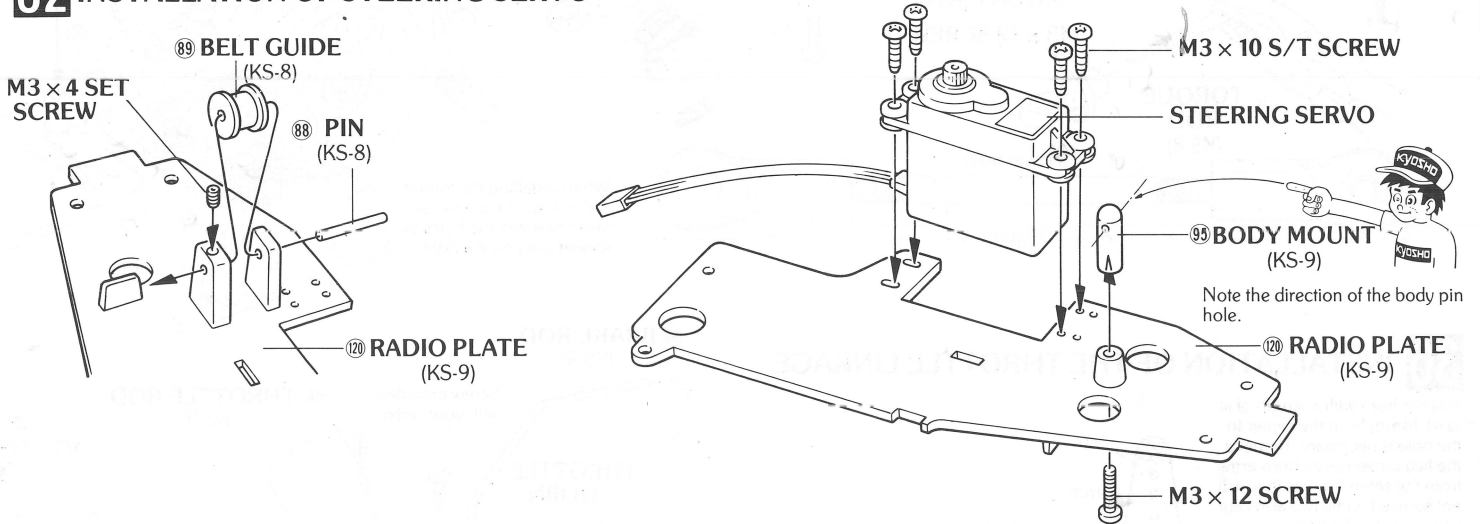

33 INSTALLATION OF RADIO PLATE

